

Thermowells for Sanitary Applications Model TW22

WIKA Data Sheet TW 95.22



Applications

- Sanitary applications
- Food industry
- Beverage industry
- Biotechnology and pharmaceutical industry, production of active ingredients
- Paint-finishing systems

Special Features

- Materials and surface finish quality in accordance with Hygienic Design standards
- Thermowell material of the wetted parts stainless steel 1.4435
- Fully welded
- Combinable with Model TR22 electrical resistance thermometer, replaceable measuring insert
- Combinable with mechanical thermometers, temperature switches, DiwiTherm®

Description

The Model TW22 thermowell is used for fitting thermometers or measuring inserts to the process, and protects the sensor against harsh process conditions. The thermowell is fitted to the appropriate hygienic connection via a weld-in socket and thus mounted into pipelines and tanks.

With a running nut to the connection head or display, it is possible to loosen these components and to adjust them in the desired position.

In combination with the Model TR22 resistance thermometer, the connection head and measuring insert, together, can be removed. This enables the thermometer and the entire measuring chain to be calibrated, without even having to disconnect the electrical connections. The process does not need to be opened and thus the risk of contamination is minimised.



Thermowells Model TW22 with welding ball (left) and connection for VARIVENT® In-Line housing (right)



Thermowells Model TW22 with aseptic connection DIN 11 864-1 (left) and Clamp connection (right)

Technical Data

Nominal size

See dimensional specification

Pressure rating PN

See dimensional specification

Material

Wetted parts: stainless steel 1.4435 (316L)

Surface roughness of the wetted parts

- $R_a < 0.8 \mu\text{m}$ (standard)

Options:

- $R_a < 0.4 \mu\text{m}$
- Electropolished $R_a < 0.4 \mu\text{m}$
- Polished and electropolished $R_a < 0.25 \mu\text{m}$

Instrument connection

In combination with:

- Model TR22 resistance thermometer
 - male nut M24 x 1.5, running
 - option: ½ NPT, fixed
- Model 55 and Model 73 mechanical thermometers
Design 3 (union nut)
 - male nut M24 x 1.5, running
 - option: mechanical thermometers in Design S (fixed),
BF 2 (running nut), BF 4 (compression fitting),
BF 5 (union nut with fitting): G ½ or ½ NPT female
thread

Thermowell diameter

- For Model TR22 resistance thermometers
 - $\varnothing 6 \times 1.4 \text{ mm}$ for $\varnothing 3 \text{ mm}$ sensors
 - $\varnothing 6 \times 1.4 \text{ mm}$ tapered to $\varnothing 4.5 \text{ mm}$ for $\varnothing 3 \text{ mm}$ sensors
(fast response)
 - $\varnothing 4.5 \text{ mm}$ for $\varnothing 3 \text{ mm}$ sensors (fast response,
insertion length U_1 : 25 mm)
 - $\varnothing 3 \text{ mm}$ for $\varnothing 2 \text{ mm}$ sensors (only for BioControl® size 25)
- For Model 55 and Model 73 mechanical thermometers,
Model TR75 DiwiTherm®, Model TR70 temperature switch
 - $\varnothing 8 \times 0.9 \text{ mm}$ for $\varnothing 6 \text{ mm}$ sensors
 - $\varnothing 12 \times 1.5 \text{ mm}$ for $\varnothing 8 \text{ mm}$ sensors

Neck tube length M

- 85 mm

Others on request

Neck tube diameter

- Model TR22 resistance thermometers
 - up to DN 20: 9 mm (except for DIN 11 851 (milk thread
fitting): 12 mm)
 - from DN 25: 12 mm
- Model 55 and Model 73 mechanical thermometers,
Model TR75 DiwiTherm®, Model TR70 temperature switch
 - same diameter as the thermowell diameter

Insertion length U_1

- Standards: 25, 50, 75, 100, 150, 200 mm
- Insertion lengths for BioControl® flow-through housing
see table page 4
- Option: up to 400 mm to customer specification

Combination options

- Model TR22 resistance thermometer
- Model 55 or Model 73 mechanical thermometers
- Model TR75 DiwiTherm®
- Model TR70 temperature switch

Combination examples

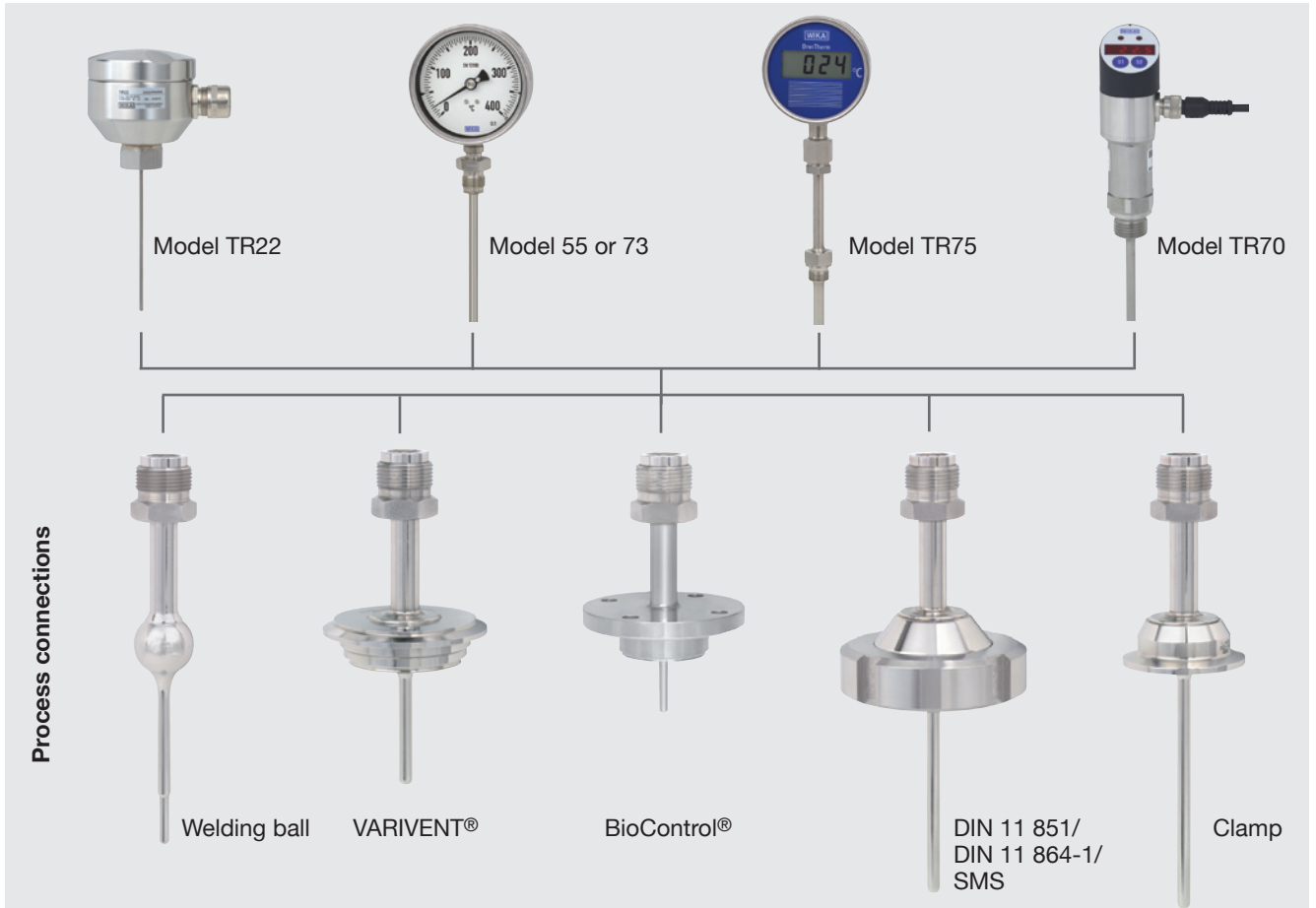

Basic thermowell design

For mechanical thermometers and temperature switches

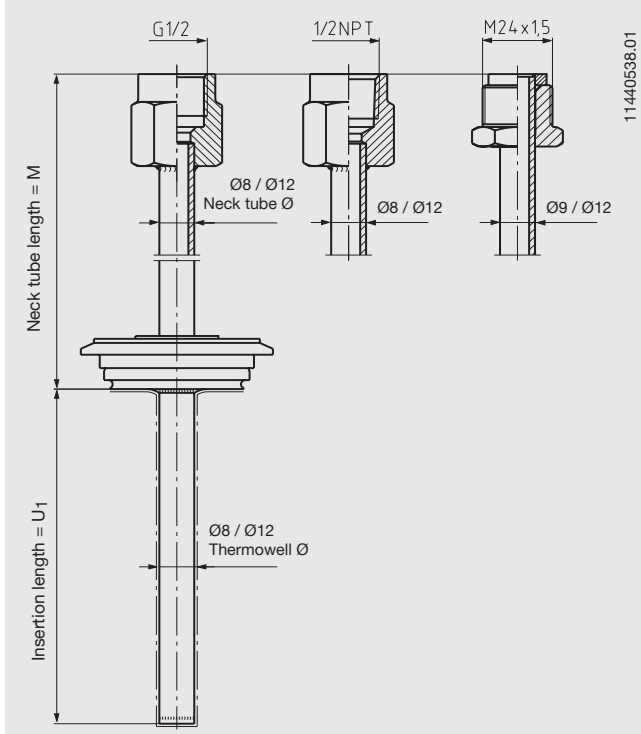

For electrical thermometers model TR22 and DiwiTherm®

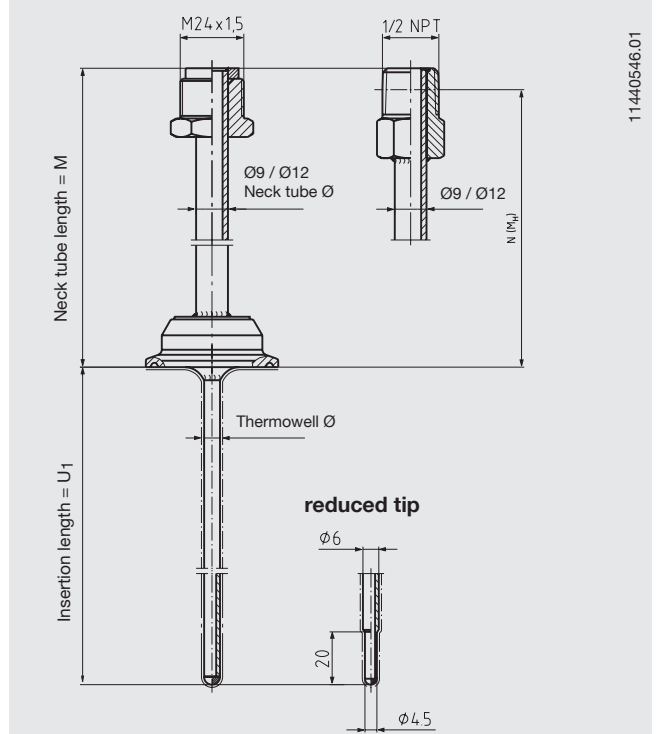

Process connections and dimensional specifications

Process connection NEUMO BioControl®

The insertion length U_1 and the thermowell diameter have been adapted for mounting in a flow-through housing. For angled housings, the insertion length U_1 must be defined by the customer.

The housings are not part of the scope of delivery of the resistance thermometers and can be ordered as a separate item. For a detailed description of the BioControl® housings, see data sheet AC 09.14.

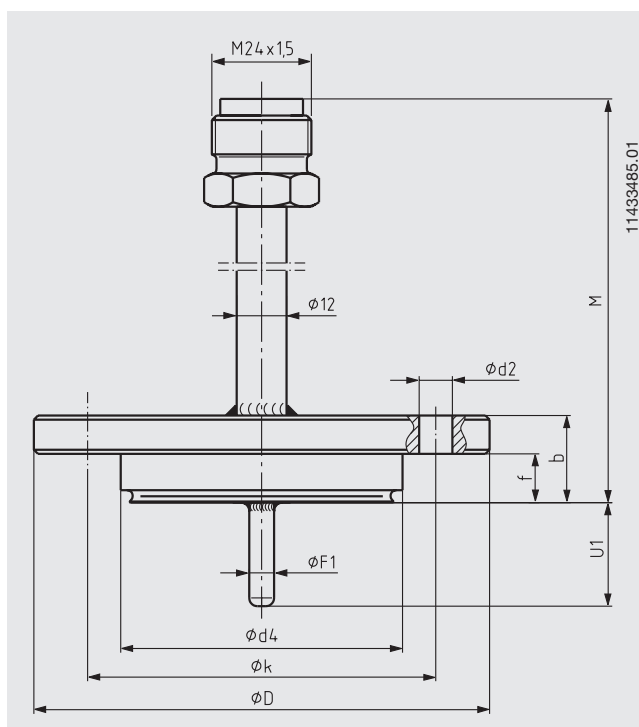

Housing size	Nominal pipe size	Dimensions in mm								Weight in kg
		U_1	$\varnothing F_1$	$\varnothing d_4$	$\varnothing D$	f	b	$\varnothing k$	$\varnothing d_2$	
Size 25	DN 8	5	3	30.5	64	11	20	50	4 x $\varnothing 7$	0.4
	DN 10	6	3	30.5	64	11	20	50	4 x $\varnothing 7$	0.4
	DN 15	9	3	30.5	64	11	20	50	4 x $\varnothing 7$	0.4
	DN 20	11	3	30.5	64	11	20	50	4 x $\varnothing 7$	0.4
Size 50	DN 25	15	6	50	90	17	27	70	4 x $\varnothing 9$	0.8
	DN 40	20	6	50	90	17	27	70	4 x $\varnothing 9$	0.8
	DN 50	25	6	50	90	17	27	70	4 x $\varnothing 9$	0.8
	DN 65	35	6	50	90	17	27	70	4 x $\varnothing 9$	0.8
	DN 80	45	6	50	90	17	27	70	4 x $\varnothing 9$	0.8
	DN 100	55	6	50	90	17	27	70	4 x $\varnothing 9$	0.8
Size 65	DN 40	20	6	68	120	17	27	95	4 x $\varnothing 11$	1.4
	DN 50	25	6	68	120	17	27	95	4 x $\varnothing 11$	1.4
	DN 65	35	6	68	120	17	27	95	4 x $\varnothing 11$	1.4
	DN 80	45	6	68	120	17	27	95	4 x $\varnothing 11$	1.4
	DN 100	55	6	68	120	17	27	95	4 x $\varnothing 11$	1.4

Process connection union nut DIN 11 851 with conical coupling (milk thread fitting)

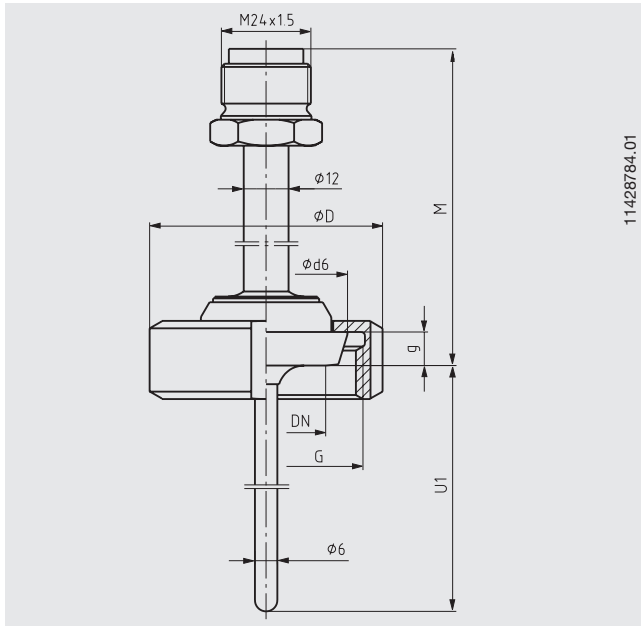

Nominal size in mm	PN in bar	Dimensions in mm				Weight in kg
		Ø d6	G	Ø D	g	
DN 20	40	36.5	RD 44 x 1/6	54	8	0.4
DN 25	40	44	RD 52 x 1/6	63	10	0.5
DN 32	40	50	RD 58 x 1/6	70	10	0.6
DN 40	40	56	RD 65 x 1/6	78	10	0.8
DN 50	25	68.5	RD 78 x 1/6	92	11	0.9

Process connection aseptic threaded connection DIN 11 864-1 with liner Form A, for pipes per DIN 11 866 series A

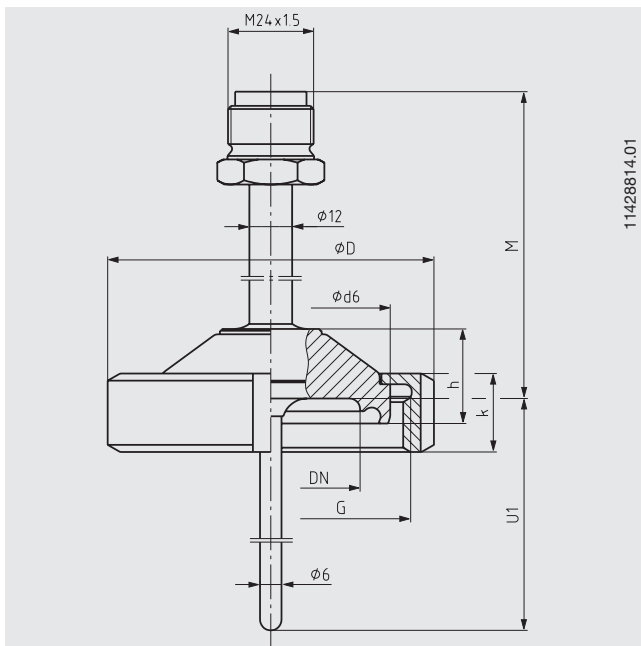

Nominal size in mm	PN in bar	Dimensions in mm					Aseptic-O-ring	Weight in kg
		Ø D	Ø d6	G	k	h		
DN 10	40	38	21.9	RD 28 x 1/8	18	9	12 x 3.5	0.2
DN 15	40	44	27.9	RD 34 x 1/8	18	9	18 x 3.5	0.2
DN 20	40	54	35.9	RD 44 x 1/6	20	10	22 x 3.5	0.25
DN 25	40	63	42.9	RD 52 x 1/6	21	20	28 x 3.5	0.4
DN 32	40	70	48.9	RD 58 x 1/6	21	20	34 x 5	0.45
DN 40	40	78	54.9	RD 65 x 1/6	21	20	40 x 5	0.55
DN 50	25	92	66.9	RD 78 x 1/6	22	20	52 x 5	0.7

**Process connection aseptic flange DIN 11 864-2 Form A
for pipes per DIN 11 866 series A**

Liner flange

Aseptic liner flange DIN 11 864-2 Form A

Flange with groove

Aseptic flange with groove DIN 11 864-2 Form A

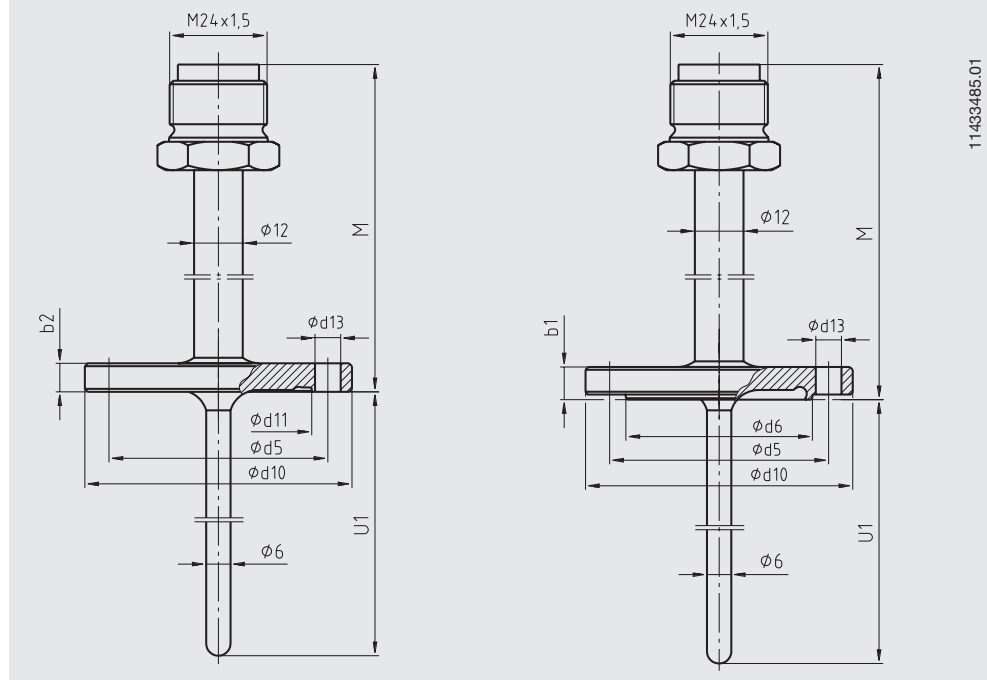

Process connection	Nominal size in mm	PN in bar	Dimensions in mm							Aseptic O-ring	Weight in kg
			Ø d ₁₀	Ø d ₁₁	Ø d ₆	Ø d ₅	Ø d ₁₃	b ₁	b ₂		
Liner flange	DN 10	25	54	22.4	-	37	4 x Ø 9	-	10	12 x 3.5	0.2
	DN 15	25	59	28.4	-	42	4 x Ø 9	-	10	18 x 3.5	0.25
	DN 20	25	64	32.4	-	47	4 x Ø 9	-	10	22 x 3.5	0.3
	DN 25	25	70	38.4	-	53	4 x Ø 9	-	10	28 x 3.5	0.1
	DN 32	25	76	47.7	-	59	4 x Ø 9	-	10	34 x 5	0.4
	DN 40	25	82	53.7	-	65	4 x Ø 9	-	10	40 x 5	0.5
	DN 50	16	94	65.7	-	77	4 x Ø 9	-	10	52 x 5	0.6
Flange with groove	DN 10	25	54	-	22.3	37	4 x Ø 9	11.5	-	12 x 3.5	0.25
	DN 15	25	59	-	28.3	42	4 x Ø 9	11.5	-	18 x 3.5	0.3
	DN 20	25	64	-	32.3	47	4 x Ø 9	11.5	-	22 x 3.5	0.3
	DN 25	25	70	-	38.3	53	4 x Ø 9	11.5	-	28 x 3.5	0.4
	DN 32	25	76	-	47.6	59	4 x Ø 9	11.5	-	34 x 5	0.45
	DN 40	25	82	-	56.6	65	4 x Ø 9	11.5	-	40 x 5	0.6
	DN 50	16	94	-	65.6	77	4 x Ø 9	11.5	-	52 x 5	0.7

**Process connection aseptic clamp connection DIN 11 864-3, Form A
for pipes per DIN 11 866 series A**

Clamp liner

Aseptic clamp liner
DIN 11 864-3 Form A

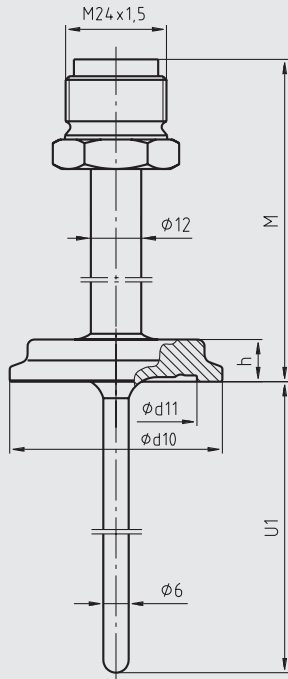

Clamp with groove

Aseptic clamp with groove
DIN 11 864-3 Form A

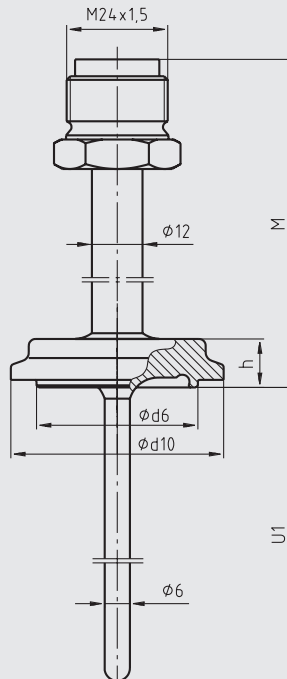

11434318.01

Process connection	Nominal size in mm	PN in bar	Dimensions in mm				Aseptic O-ring	Weight in kg
			ϕd_{10}	ϕd_{11}	ϕd_6	h		
Clamp liner	DN 10	40	34	22.4	-	10	12 x 3.5	0.2
	DN 15	40	34	28.4	-	10	18 x 3.5	0.2
	DN 20	40	50.5	32.4	-	10	22 x 3.5	0.3
	DN 25	40	50.5	38.4	-	10	28 x 3.5	0.3
	DN 32	40	50.5	47.7	-	10	34 x 5	0.3
	DN 40	40	64	53.7	-	10	40 x 5	0.4
DN 50	25	77.5	65.7	-	10	52 x 5	0.5	
Clamp with groove	DN 10	40	34	-	22.3	11.5	12 x 3.5	0.2
	DN 15	40	34	-	28.3	11.5	18 x 3.5	0.2
	DN 20	40	50.5	-	32.3	11.5	22 x 3.5	0.3
	DN 25	40	50.5	-	38.3	11.5	28 x 3.5	0.3
	DN 32	40	50.5	-	47.6	11.5	34 x 5	0.3
	DN 40	40	64	-	53.6	11.5	40 x 5	0.4
DN 50	25	77.5	-	65.6	11.5	52 x 5	0.5	

Clamp process connection

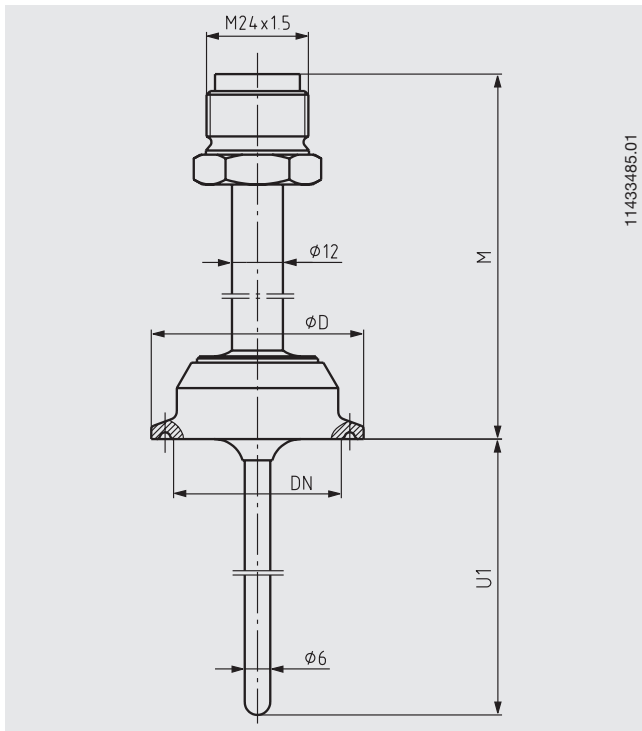

Process connection	Nominal size in mm/in.	PN in bar	Dimensions in mm ϕD	Weight in kg
DIN 32 676	DN 10 ... 20	16	34	0.2
	DN 25 ... 40	16	50	0.3
	DN 50	16	64	0.4
TRI-Clamp	1/2"	16	25	0.2
	3/4"	16	25	0.2
	1"	16	50	0.3
	1 1/2"	16	50	0.3
	2"	16	64	0.4
ISO 2852	DN 12 ... 21.3	16	34	0.2
	DN 25 ... 38	16	50	0.3
	DN 40 ... 51	16	64	0.4

VARIVENT® process connection

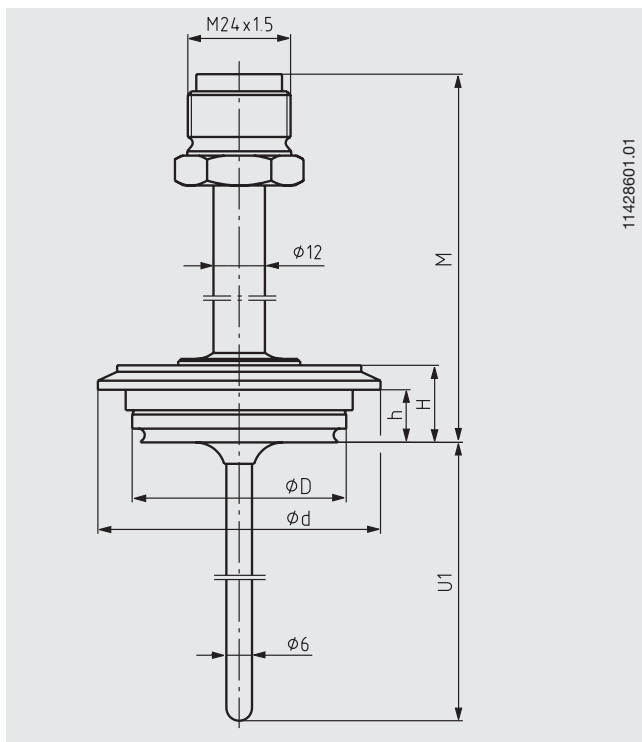

Process connection	Nominal size in mm	PN in bar	Dimensions in mm				Weight in kg
			ϕD	ϕd	H	h	
Form B	DN 10, DN 15	25	31	52.7	20	13.65	0.3
Form F	DN 25, DN 32	25	50	66	18	12.3	0.4
Form N	DN 40, DN 50	25	68	84	18	12.3	0.6

Process connection compression fitting

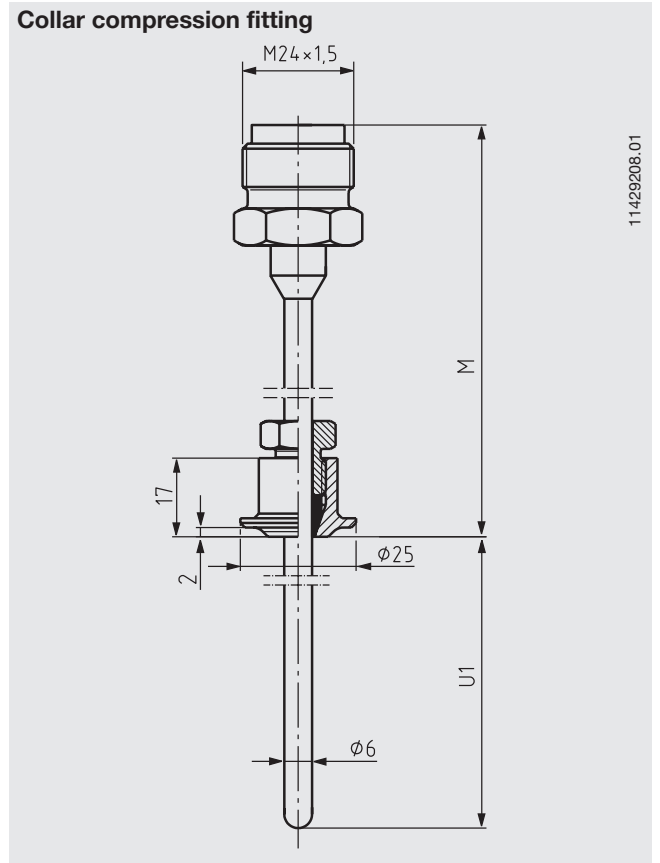
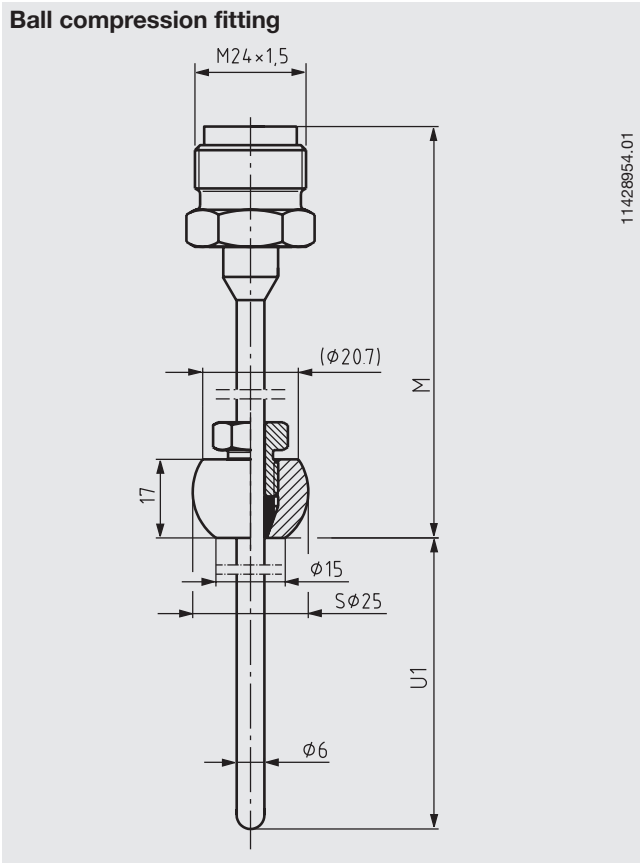

Process connection straight, Ø 6 mm, basic design of compression fitting

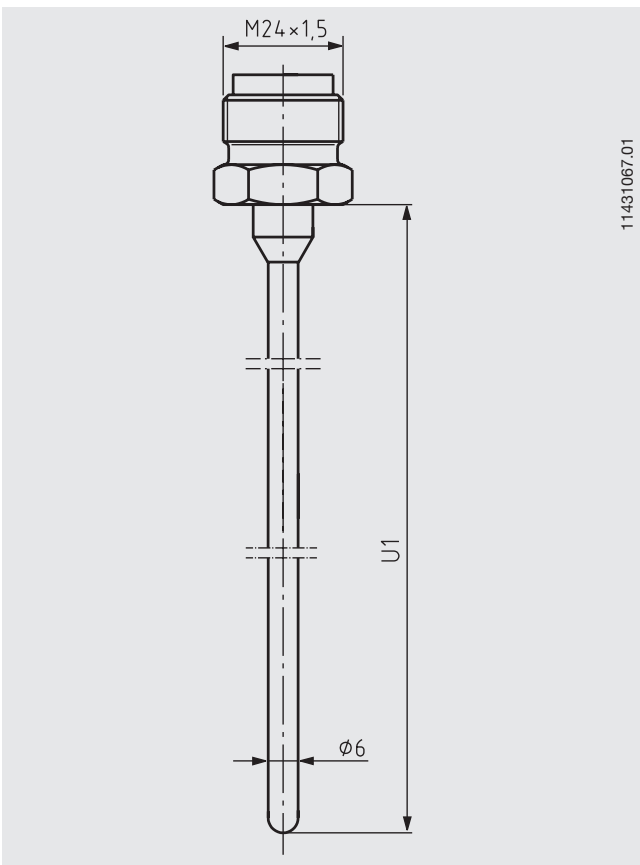

Process connection welding ball

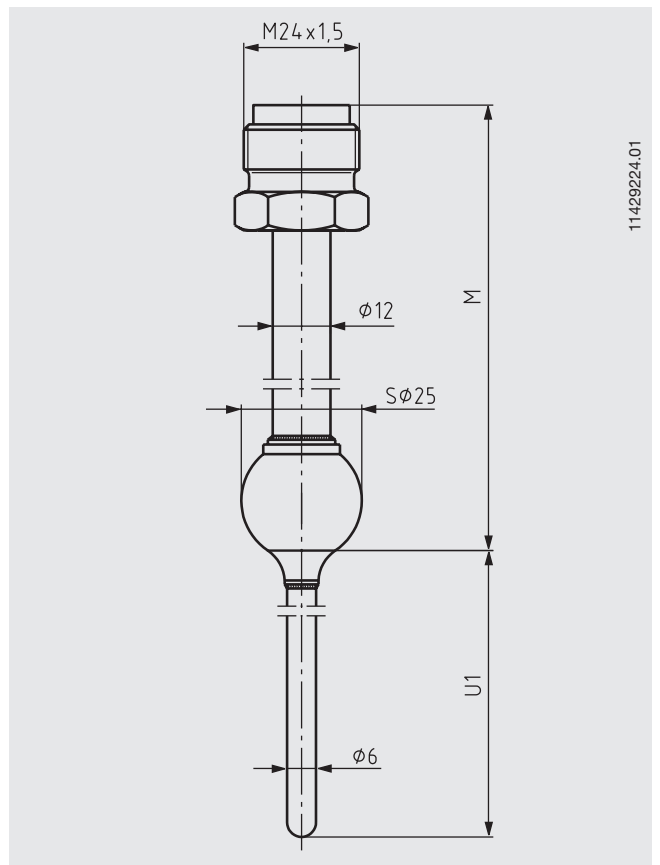

Process connection union nut SMS

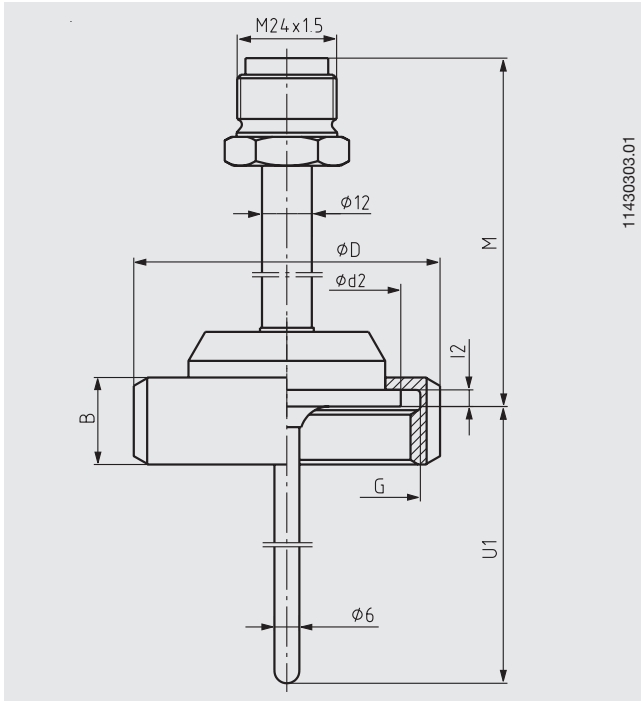

Nominal size in inch	PN in bar	Dimensions in mm					Weight in kg
		ϕD	ϕd_2	B	l_2	G	
1"	40	51	35.5	25	3.5	RD 40 x $\frac{1}{6}$	0.4
1½"	40	74	55	25	4	RD 60 x $\frac{1}{6}$	0.8
2"	40	84	65	26	4	RD 70 x $\frac{1}{6}$	1

Ordering information

Process connection design / Nominal size / Thermowell material / Surface roughness of the wetted parts / Instrument connection (N) / Insertion length U_1 / Thermowell diameter / Neck tube length M / Neck tube diameter / Assembly with resistance thermometers / Thermometer / Certificates / Additional ordering information

Modifications may take place and materials specified may be replaced by others without prior notice.
Specifications and dimensions given in this leaflet represent the state of engineering at the time of printing.



WIKA Alexander Wiegand GmbH & Co. KG
 Alexander-Wiegand-Straße 30
 63911 Klingenberg/Germany
 Tel. (+49) 9372/132-0
 Fax (+49) 9372/132-406
 E-mail info@wika.de
 www.wika.de