

# Expansion thermometer Stainless steel version, model 70

WIKA data sheet TM 81.01

## Applications

- General-purpose temperature measuring instruments for gaseous, liquid and highly-viscous process media in harsh working environments
- Refrigeration industry
- Machine building

## Special features

- Case and stem made of stainless steel
- Design per DIN EN 13190
- Different designs of connection and mounting
- With capillary
- With various fixed connections



Fig. left: expansion thermometer model M70.50.100  
Fig. right: expansion thermometer model B70.50.063

## Description

This series of thermometers is universally suitable for machine building, refrigeration and air-conditioning industry. Expansion thermometers can be installed in or mounted at nearly all locations. Versions with capillaries are used in locations which are not easily accessible and where long distances have to be bridged.

Case, capillary, stem and process connection are made from stainless steel. Various insertion lengths and process connections are available to match the requirements of each measuring location optimally.

## Standard version

### Measuring principle

Bourdon tube system

### Nominal size in mm

63, 100, 160

### Design of connection

- 1 Plain stem (without thread)
- 2 Male nut
- 3 Union nut
- 4 Compression fitting (sliding on stem)
- 5 Union nut with fitting
- 6 Compression fitting (sliding on capillary)

### Instrument version and type of mounting

- B Instruments with capillary; centre back mount triangular bezel with bracket
- H Instruments with capillary; lower mount (radial) surface mounting flange
- M Instruments with capillary; lower mount (radial) surface mounting bracket, aluminium die cast
- V Instruments with capillary; back mount <sup>1)</sup> panel mounting flange
- A Back mount <sup>1)</sup>, fix plain stem, threaded connection or thermowell
- R Lower mount (radial), fix plain stem, threaded connection or thermowell
- S Back mount <sup>1)</sup>, fix plain stem, threaded connection or thermowell; swivelling approx. 90 °

1) eccentric; NS 63: centric

### Fill medium

Xylol or silikon oil

### Accuracy class

Class 2

### Rated operating ranges and conditions

DIN EN 13190

### Capillary entry

Lower or back

### Case

Stainless steel

### Bezel ring

Stainless steel

### Connection

Stainless steel 1.4571

### Capillary

Length to customer specifications (max. 10 m), Ø 2 mm, stainless steel 1.4571, bending radius not less than 6 mm

### Stem

Ø 8 mm, stainless steel 1.4571

### Active length of sensor

Depending on Ø d and scale range

### Dial

Aluminium, white, black lettering

### Pointer

Aluminium, black

### Window

NS 100, 160: Instrument glass

NS 63: Transparent plastic

### Temperature limits for storage and transport

-50 ... +70 °C (DIN EN 13190) without liquid damping

-20 ... +60 °C (DIN EN 13190) with food-compatible liquid damping

-50 ... +60 °C (DIN EN 13190) with liquid damping

### Ambient temperature limit at the case

0 ... +40 °C max. (others on request)

### Pressure rating of stem

25 bar max., static

### Ingress protection

IP 65 per EN 60529 / IEC 529

## Options

- Scale range °F, °C/°F (dual scale)
- Laminated safety glass, clear plastic
- Ambient temperature compensation
- Accuracy class 1.0
- Thermowell per DIN or to customer specification
- Surface mounting bracket from other materials and in other lengths (A)
- Liquid filling with
  - NS 63: Model X70.53.063
  - NS 100: Model X70.53.100
  - NS 160: Model X70.53.160
- Spiral protecting hose stainless steel
- Designs per DIN EN ISO 13485, medical applications on request
- Model 70 with micro switch see WIKA data sheet TV 28.01
- Stem Ø 6, 10 mm

## Scale ranges, measuring ranges <sup>1)</sup>

Scale range in °C	Measuring range in °C	Limit error ± °C	Scale division in °C
-60 ... +40	-50 ... +30	2	1
-40 ... +60	-30 ... +50	2	1
-30 ... +50	-20 ... +40	2	1
-20 ... +60	-10 ... +50	2	1
-20 ... +80	-10 ... +70	2	1
0 ... +60	+10 ... +50	2	1
0 ... +80	+10 ... +70	2	1
0 ... +100	+10 ... +90	2	1
0 ... +120	+10 ... +110	4	2
0 ... +160	+20 ... +140	4	2
0 ... +200	+20 ... +180	4	2
0 ... +250	+30 ... +220	5	5
0 ... +300	+30 ... +270	10	10
0 ... +400	+50 ... +350	10	10

Other scale ranges on request.

<sup>1)</sup> The measuring range is indicated on the dial by two triangular marks.  
The stated limit of error per DIN EN 13190 is only valid within this range.

## Models

Model	NS	Connection location	Type of mounting
<b>B70.50</b> (instruments without liquid filling) <b>B70.53</b> (instruments with liquid filling)	063	centre back mount	Triangular bezel with bracket
<b>H70.50</b> (instruments without liquid filling) <b>H70.53</b> (instruments with liquid filling)	063 100 160	lower mount (radial)	Surface mounting flange
<b>M70.50</b> (instruments without liquid filling) <b>M70.53</b> (instruments with liquid filling)	063 100 160	lower mount (radial)	Surface mounting bracket
<b>V70.50</b> (instruments without liquid filling) <b>V70.53</b> (instruments with liquid filling)	063 100 160	centre back mount lower back mount	Panel mounting flange
<b>A70.50</b> (instruments without liquid filling) <b>A70.53</b> (instruments with liquid filling)	063 100	centre back mount, fix lower back mount, fix	via connection (plain stem), threaded connection or thermowell
<b>R70.50</b> (instruments without liquid filling) <b>R70.53</b> (instruments with liquid filling)	063 100	lower mount (radial), fix	via connection (plain stem), threaded connection or thermowell
<b>S70.50</b> (instruments without liquid filling) <b>S70.53</b> (instruments with liquid filling)	063 100	centre back mount, fix lower back mount, fix	via connection (plain stem), threaded connection or thermowell; swivelling approx. 90 °

## Dimensions in mm

**Model M70, surface mounting bracket**

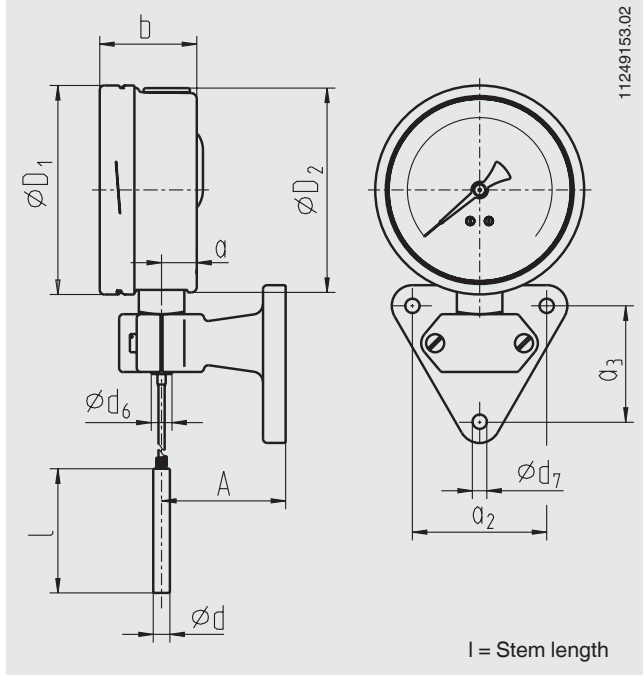

**Model H70, surface mounting flange**

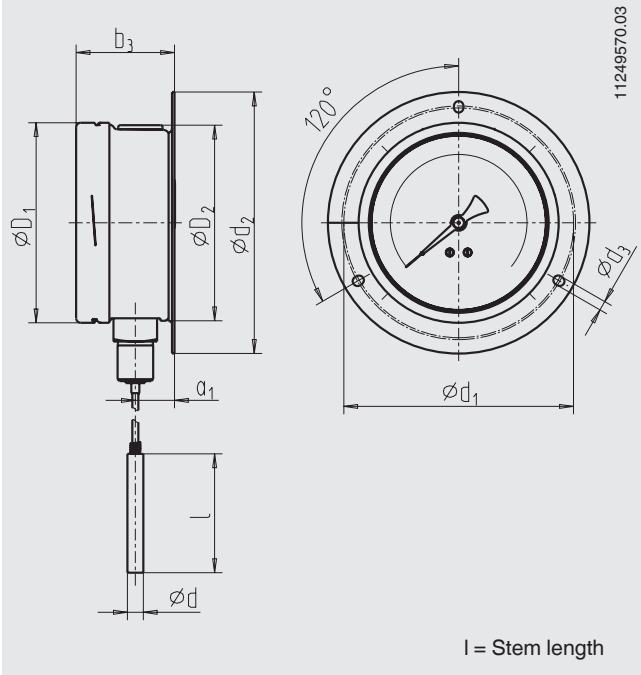

**Model V70, panel mounting flange**

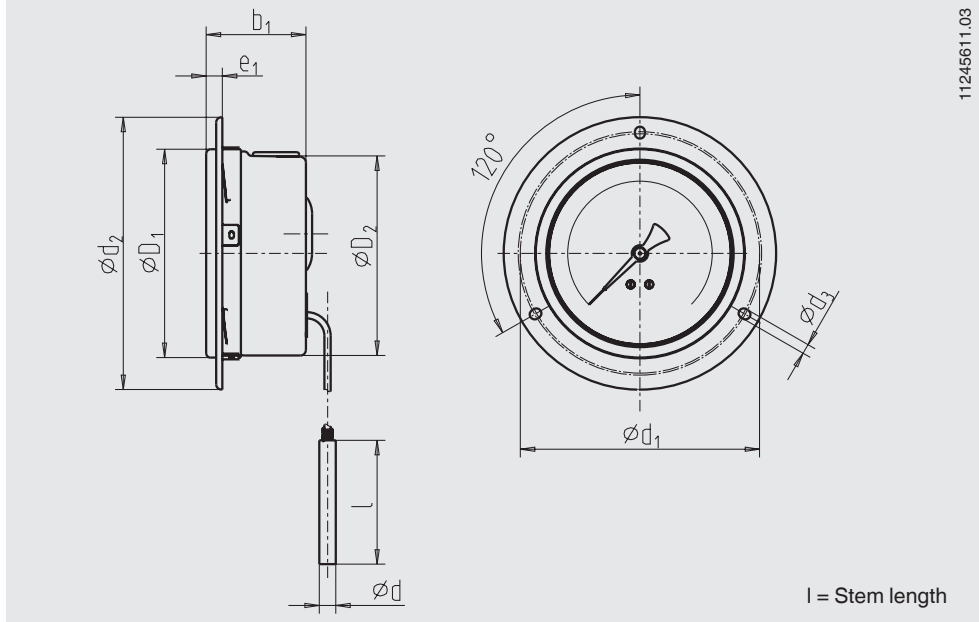

**Model B70, triangular bezel with bracket**

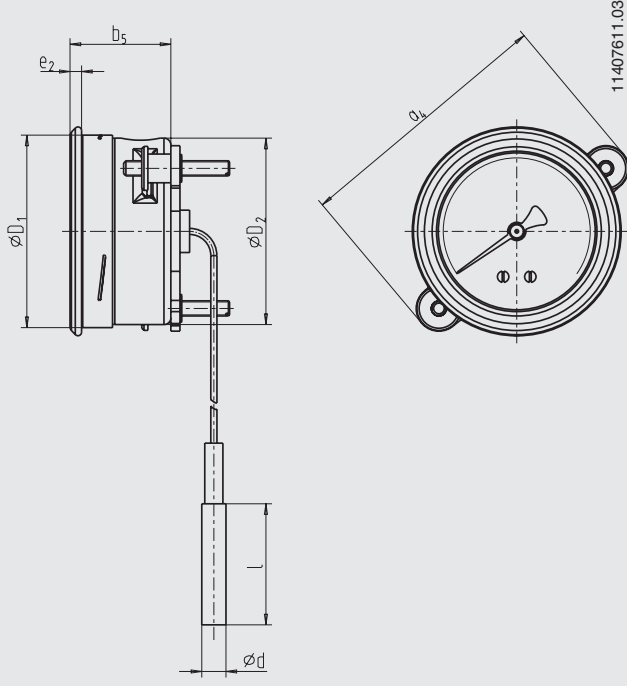

11407611.03

$I$  = Stem length

**Model R70, lower mount**

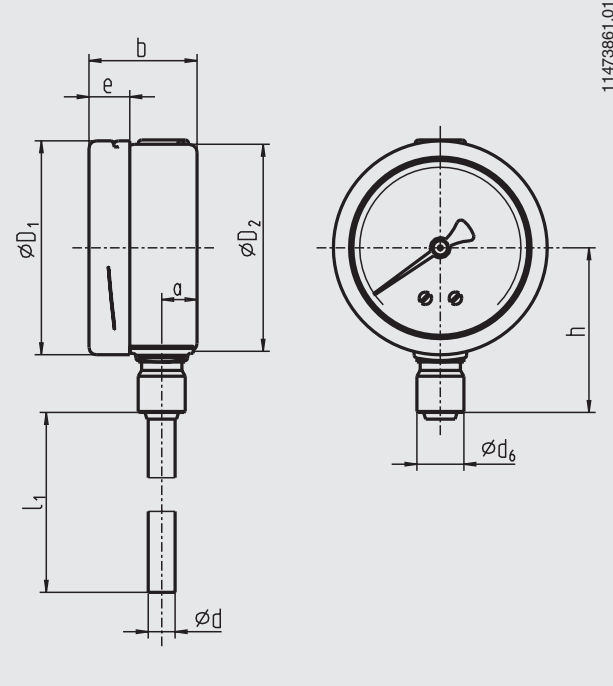

11473861.01

$l_1$  = Stem length

**Model S70, case swivelling approx. 90°**

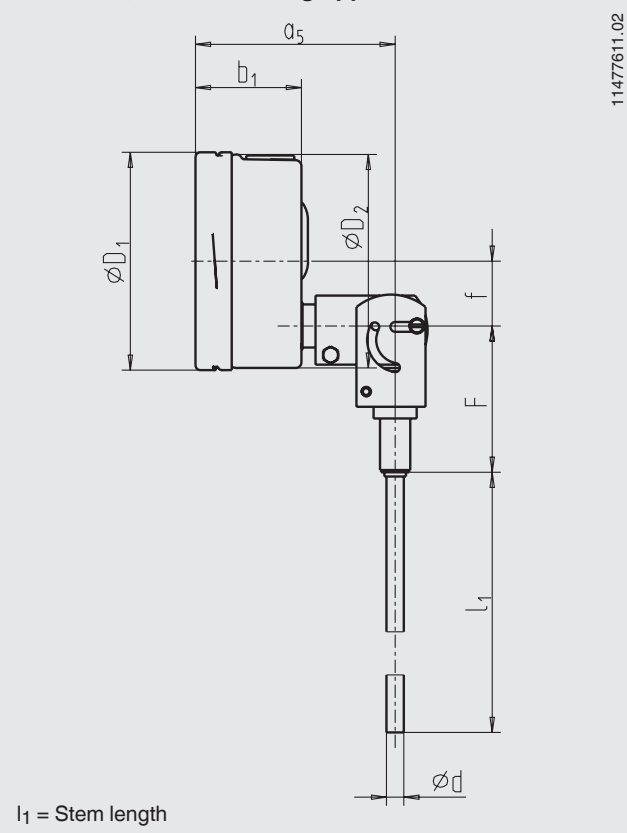

11477611.02

$l_1$  = Stem length

**Model A70, back mount (NS 100)**

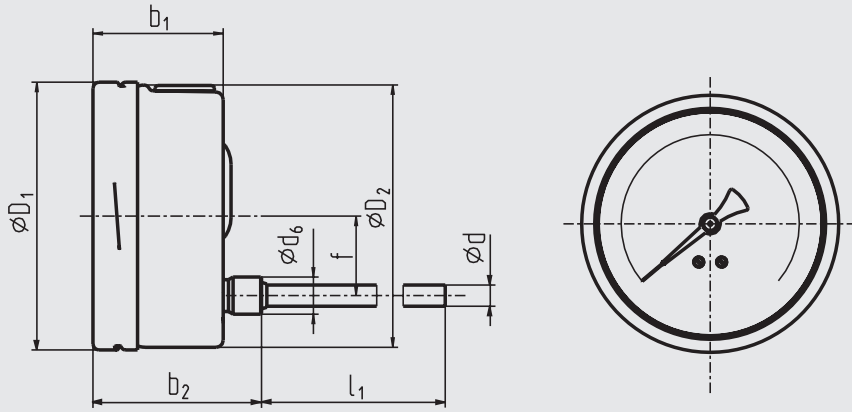

11473895.01

$l_1$  = Stem length

**Model A70, back mount (NS 63)**

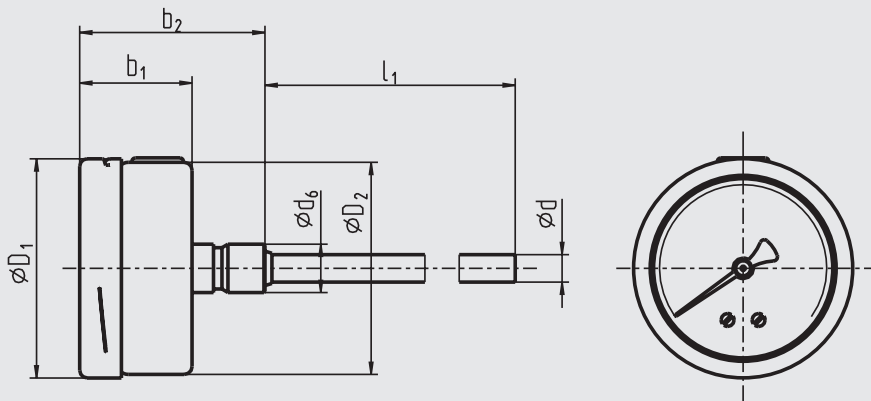

11473658.02

$l_1$  = Stem length

NS	Dimensions in mm												
	a	a <sub>1</sub>	a <sub>2</sub>	a <sub>3</sub>	a <sub>4</sub>	a <sub>5</sub>	b	b <sub>1</sub>	b <sub>2</sub>	b <sub>3</sub>	b <sub>5</sub>	Ø d	Ø d <sub>1</sub>
63	10.5	13	65	56	87	83	32.5	32.5	54.0	34.5	33.5	8	75
100	15.5	22	65	56	-	93	49.5	49.5	63.5	50.0	-	8	116
160	15.5	22	65	56	-	-	49.5	-	-	50.0	-	8	178

NS	Dimensions in mm													Weight in kg
	Ø d <sub>2</sub>	Ø d <sub>3</sub>	Ø d <sub>6</sub>	Ø d <sub>7</sub>	e	e <sub>1</sub>	e <sub>2</sub>	f	h	A	Ø D <sub>1</sub>	Ø D <sub>2</sub>	F	
63	85	3.6	14	7	12.2	5	4	0	49.0	60	63.5	62	68	0.4
100	132	4.8	18	7	16.8	8	-	30	68.5	60	101.0	99	68	0.9
160	196	6.0	18	7	16.8	8	-	-	-	60	161.0	159	-	1.4

## Design of connection per DIN

### Design 1, plain connection (without thread)

Stem length in mm:  $l = 140, 200, 240, 290$   
 (Basis for design 4, compression fitting)

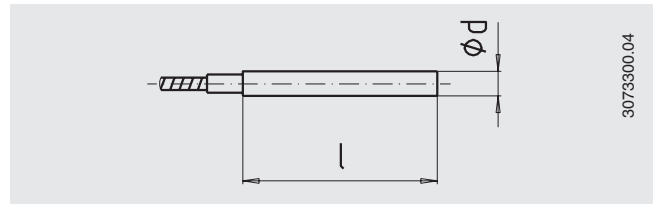

3073300.04

### Design 2, male nut

Process connection: G 1/2 B

Stem length in mm:  $l_1 = 80, 140, 180, 230$

Process connection	Dimensions in mm	
G	SW	i
G 1/2 B	27	20

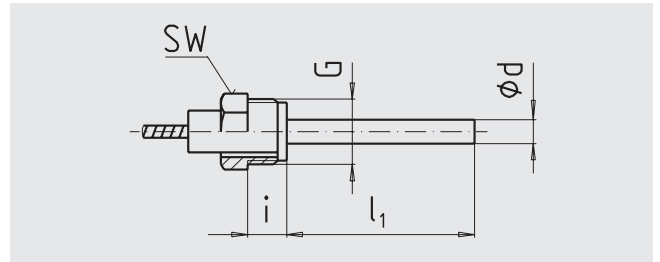

### Design 3, union nut

Process connection: G 1/2, G 3/4, M24 x 1.5

Stem length in mm:  $l_1 = 89, 126, 186, 226, 276$

Process connection	Dimensions in mm	
G	SW	i
G 1/2	27	8.5
G 3/4	32	10.5
M24 x 1.5	32	13.5

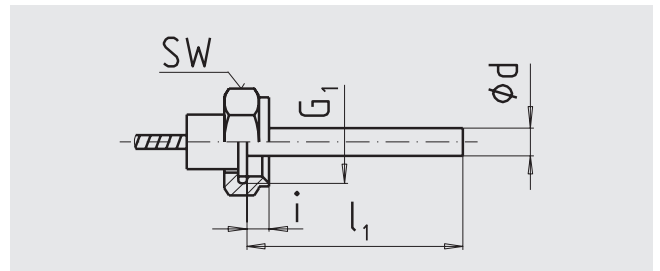

### Design 4, compression fitting (sliding on stem)

Process connection: G 1/2 B, G 3/4 B, M18 x 1.5 as well as  
 1/2 NPT, 3/4 NPT

Stem length in mm:  $l_1 = 100, 160, 200, 250$

(the stem length used can be reduced to a minimum  
 immersion length of  $l_{min} = 60$  mm)

Process connection	Dimensions in mm		
G	SW	d4	i
G 1/2 B	27	26	14
G 3/4 B	32	32	16
M18 x 1.5	24	23	12
1/2 NPT	22	-	19
3/4 NPT	30	-	20

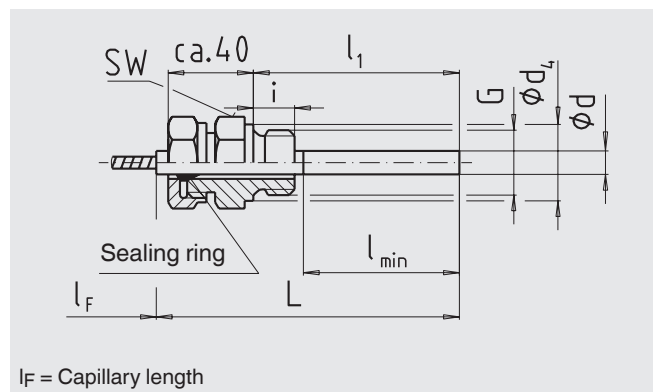

$l_F$  = Capillary length

### Design 5, union nut with fitting

Union nut: G 1/2  
 Process connection: G 1/2 B, G 3/4 B or 1/2 NPT, 3/4 NPT

Option:  
 Union nut: M24 x 1.5  
 Process connection: M18 x 1.5  
 Stem length in mm:  $l_1 = 63, 100, 160, 200, 250$

Process connection G	Dimensions in mm		
	SW	$d_4$	i
G 1/2 B	27	26	14
G 3/4 B	32	32	16
M18 x 1,5	24	23	12
1/2 NPT	22	-	19
3/4 NPT	30	-	20

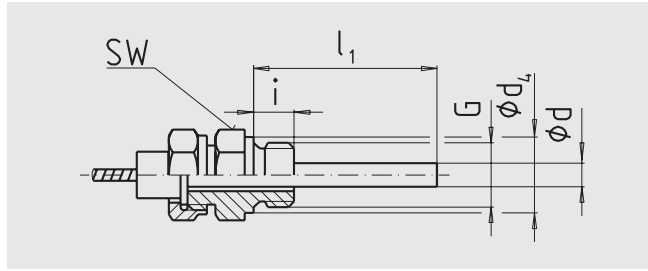

### Design 6, compression fitting (sliding on capillary)

Process connection: G 1/2 B, G 3/4 B or 1/2 NPT, 3/4 NPT  
 Stem length in mm:  $l = 100, 140, 200, 240, 290$

Process connection G	Dimensions in mm		
	SW	$d_4$	i
G 1/2 B	27	26	14
G 3/4 B	32	32	16
1/2 NPT	22	-	19
3/4 NPT	30	-	20

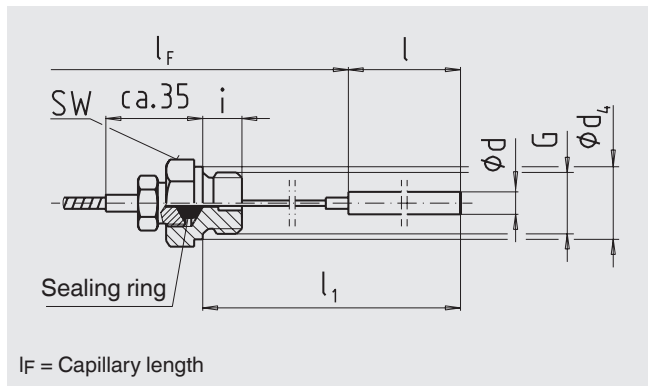

### Ordering information

Model / Nominal size / Type of mounting / Design of connection / Scale range / Process connection / Stem- $\phi$  and -length / Capillary design and length / Options

© 2009 WIKA Alexander Wiegand SE & Co. KG, all rights reserved.  
 The specifications given in this document represent the state of engineering at the time of publishing.  
 We reserve the right to make modifications to the specifications and materials.



**WIKAL Alexander Wiegand SE & Co. KG**  
 Alexander-Wiegand-Straße 30  
 63911 Klingenberg/Germany  
 Tel. (+49) 9372/132-0  
 Fax (+49) 9372/132-406  
 E-mail info@wika.de  
 www.wika.de