

Bimetal thermometer Model 53, process industry series

WIKA data sheet TM 53.01



Applications

- Chemical industry, petrochemical industry, process technology and food industry
- Facility management
- For aggressive medium

Special features

- Universal application
- Case and stem from stainless steel
- Bimetal with zero point adjustment at the back of the case
- Nominal size 3" and 5"

Description

This series of thermometers is designed for installation in pipes, vessels, plant and machinery.

Sheath and case are made of stainless steel. To allow fitting to the process, different installation lengths and process connections are available. Through the high protection class of the thermometer (IP 65) and its liquid damping, operation under high vibration conditions is possible.

The imperial nominal sizes are commonly used in North American and related markets.



Bimetal thermometer

Fig. left: back mount (axial), model A5301

Fig. right: adjustable stem and dial version, model S5301

Standard version

Measuring element

Bimetal coil

Nominal size

3", 5"

Connection design

S Standard (male thread connection) ¹⁾

1 Plain stem (without thread)

2 Male nut

3 Union nut (female)

4 Compression fitting (sliding on stem)

5 Union nut with fitting

1) Not for version "adjustable stem and dial"

Models

Model	NS	Version
A5300	3"	Back mount (axial)
A5301	5"	
S5300	3"	Back mount, adjustable stem and dial
S5301	5"	

Accuracy class

DIN EN 13190

Working pressure

Normal (1 year): Measuring range (DIN EN 13190)

Short time (24 h max.): Scale range (DIN EN 13190)

Case, bezel ring, stem, process connection

Stainless steel

Elbow behind the case

Aluminium, only with lower mount version

Dial

Aluminium white, black lettering

Window

Instrument glass

Pointer

Aluminium, black, adjustable pointer

Zero adjustment

on the rear of the case, external

Permissible pressure rating of stem

max. 25 bar, static

Permissible ambient temperature at case

+60 °C max. (others on request)

Temperature limits for storage and transport

-20 ... 60 °C (DIN EN 13190)

Ingress protection

IP 65 per EN 60529 / IEC 529

Options

- Scale range °F, °C/°F (dual scale)
- Liquid damping up to max. 250 °C (at the sensor)
- Laminated safety glass, acrylic plastic
- Stem Ø 6, 10 mm
- Ingress protection IP 66
- Special measuring ranges or dial printing to customer specifications (on request)
- Version per ATEX Ex II 2 GD c TX

Scale and measuring ranges ²⁾ (DIN EN 13190)

Scale graduation per WIKA standard

Scale range in °C	Measuring range ²⁾ in °C	Scale spacing in °C
-50 ... +50	-40 ... +40	1
-30 ... +50	-20 ... +40	0.5
-20 ... +100	-10 ... +90	1
-20 ... +120	-10 ... +110	1
0 ... +60	+10 ... +50	0.5
0 ... +80	+10 ... +70	1
0 ... +100	+10 ... +90	1
0 ... +120	+10 ... +110	1
0 ... +160	+20 ... +150	2
0 ... +200	+20 ... +180	2
0 ... +250	+30 ... +220	2
0 ... +300	+30 ... +270	5
0 ... +400	+50 ... +350	5
0 ... +500	+40 ... +450	5

Scale range in °F	Measuring range ²⁾ in °F	Scale spacing in °F
-80 ... +120	-60 ... +100	2
-20 ... +120	0 ... +100	2
0 ... +210	+20 ... +140	2
0 ... +250	+30 ... +220	2
+30 ... +400	+80 ... +350	5

2) The measuring range is indicated on the dial by two triangular marks. Only within this range is the stated error limit valid per DIN EN 13190.

Connection design

Design standard (male thread connection) ¹⁾

Connection, male: ¼ NPT, ½ NPT, G ¼ B, G ½ B

Stem length $l_1 = 2,5", 4", 6", 9", 12", 15", 18", 24"$

$l_1 = 63, 100, 150, 225, 305, 380, 455, 610$ mm

Nominal size NS	Process connection		Dimensions in mm		
	G	i	SW	d ₄	Ø d
3", 5"	¼ NPT	15	17	-	8
	½ NPT	19	22	-	8
	G ¼ B	12	22	18	8
	G ½ B	14	27	26	8

1) Not for version "adjustable stem and dial"

Design 1, plain stem (without thread)

Stem length $l = 140, 200, 240, 290$ mm

Nominal size NS	Dimensions in mm			
	d ₁	Ø d	a for axial	a for adjustable stem and dial
3", 5"	18	8	15	25

Design 2, male nut

Stem length $l_1 = 80, 140, 180, 230$ mm

Nominal size NS	Process connection		Dimensions in mm	
	G	i	SW	Ø d
3", 5"	G ½ B	20	27	8
	M18 x 1.5	12	24	8

Design 3, union nut

Stem length $l_1 = 89, 126, 186, 226, 276$ mm

Nominal size NS	Process connection		Dimensions in mm	
	G ₁	i	SW	Ø d
3", 5"	G ½	8.5	27	8
	G ¾	10.5	32	8
	M24 x 1.5	13.5	32	8

Design 4, compression fitting (sliding on stem)

Standard stem length $l_1 = 63, 100, 160, 200, 250$ mm

Length $L = l_1 + 40$ mm

Nominal size NS	Process connection		Dimensions in mm		
	G	i	SW	d ₄	Ø d
3", 5"	G ½ B	14	27	26	8
	G ¾ B	16	32	32	8
	M18 x 1.5	12	24	23	8
	½ NPT	19	22	-	8
	¾ NPT	20	30	-	8

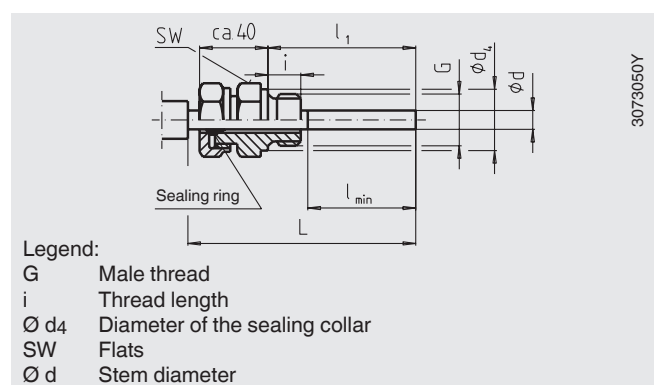
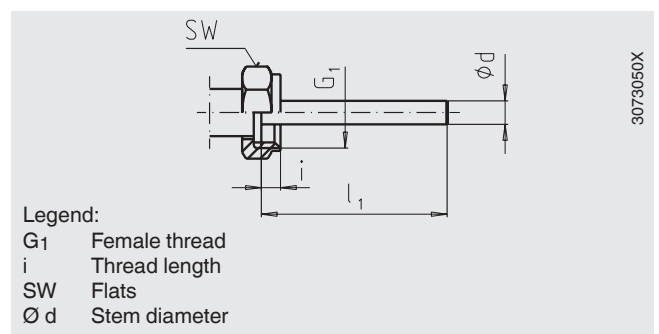
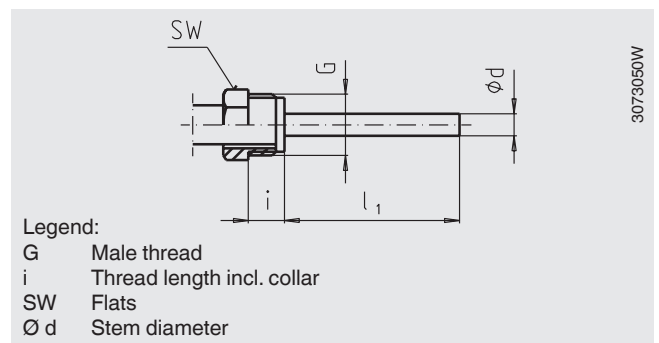
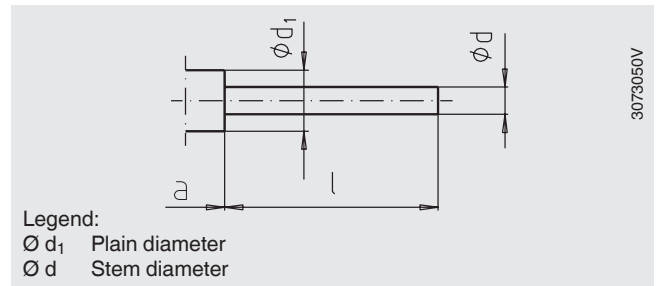
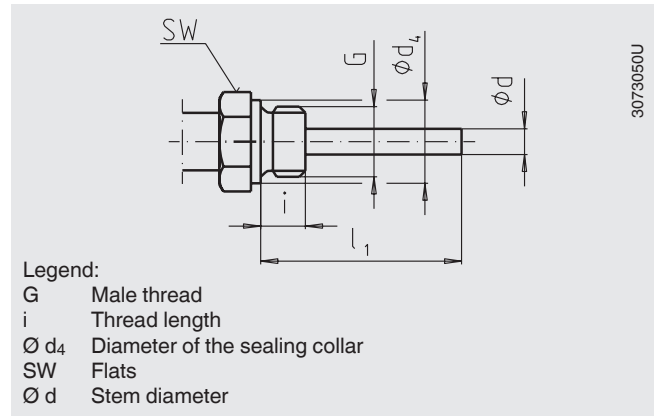

Design 5, union nut with loose fitting

Standard stem length $l_1 = 63, 100, 160, 200, 250$ mm

Nominal size NS	Process connection		Dimensions in mm		
	G	i	SW	d_4	$\varnothing d$
3", 5"	G 1/2 B	14	27	26	8
	G 3/4 B	16	32	32	8
	M18 x 1.5	12	24	23	8
	1/2 NPT	19	22	-	8
	3/4 NPT	20	30	-	8

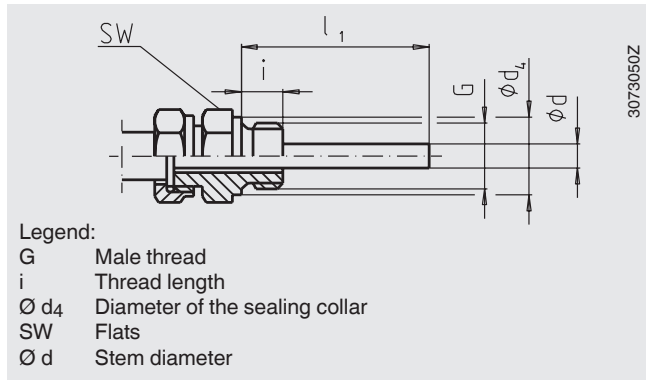

Dimensions in mm

Back mount (axial)
Model A53

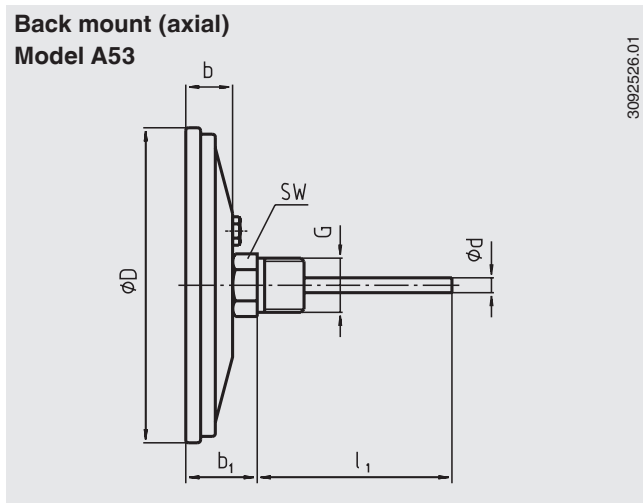

Back mount, adjustable stem and dial
Model S53

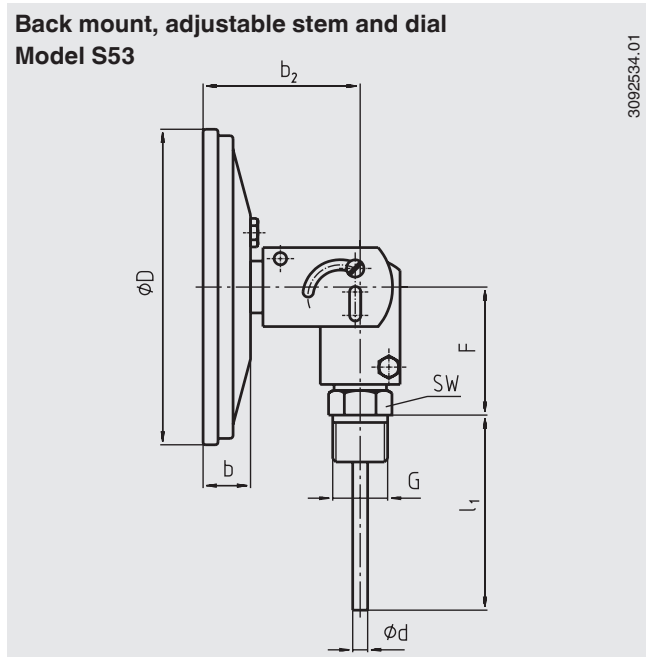

NS	Dimensions in mm						Weight in kg				
	$\varnothing D$	$\varnothing d$	b	b_2	F	b_1	G 1/4 B	1/4 NPT	G 1/2 B	1/2 NPT	Model A53xx
3"	76	6	20	63	55	32	28	35	35	0.30	0.40
5"	127	6	20	63	55	32	28	35	35	0.40	0.50

Ordering information

Model / Nominal size / Scale range / Connection size / Connection location / Options

© 2008 WIKA Alexander Wiegand SE & Co. KG, all rights reserved.
The specifications given in this document represent the state of engineering at the time of publishing.
We reserve the right to make modifications to the specifications and materials.



WIKAL Alexander Wiegand SE & Co. KG
Alexander-Wiegand-Straße 30
63911 Klingenberg/Germany
Tel. (+49) 9372/132-0
Fax (+49) 9372/132-406
E-mail info@wika.de
www.wika.de