

Electrical Cable Thermometers for Shipbuilding Industry

Model TC192, Thermocouples, Thread Mounted

Model TR192, Resistance Thermometers, Thread Mounted

WIKA Data Sheet TE 69.05



Applications

- Exhaust gas temperature measurement on diesel engines and turbines
- For onshore / offshore applications

Special Features

- Ingress protection IP 67
- Shock and vibration resistant per DIN 60 751 and IEC 751
- Quick response time, tapered thermowell
- Media temperatures:
 - TC192: 0 °C ... 850 °C
 - TR192: 0 °C ... 600 °C
- Approvals:
 - TC192: Germanischer Lloyd and Lloyd's Register
 - TR192: DNV, Lloyd's Register

Description

Electrical thermometers for measuring exhaust gas temperature on diesel engines and turbines. The standard temperature range is 0 °C ... 850 °C with thermocouples, 0 °C ... 600 °C with resistance thermometers. The thermowells are designed for loads on medium to large sized machines.

The steel-braided silicone-glass filament cable of model TC192 is suitable for ambient temperatures up to 200 °C. The application range of model TR192 is limited to 250 °C due to its steel-braided PTFE-glass filament cable.

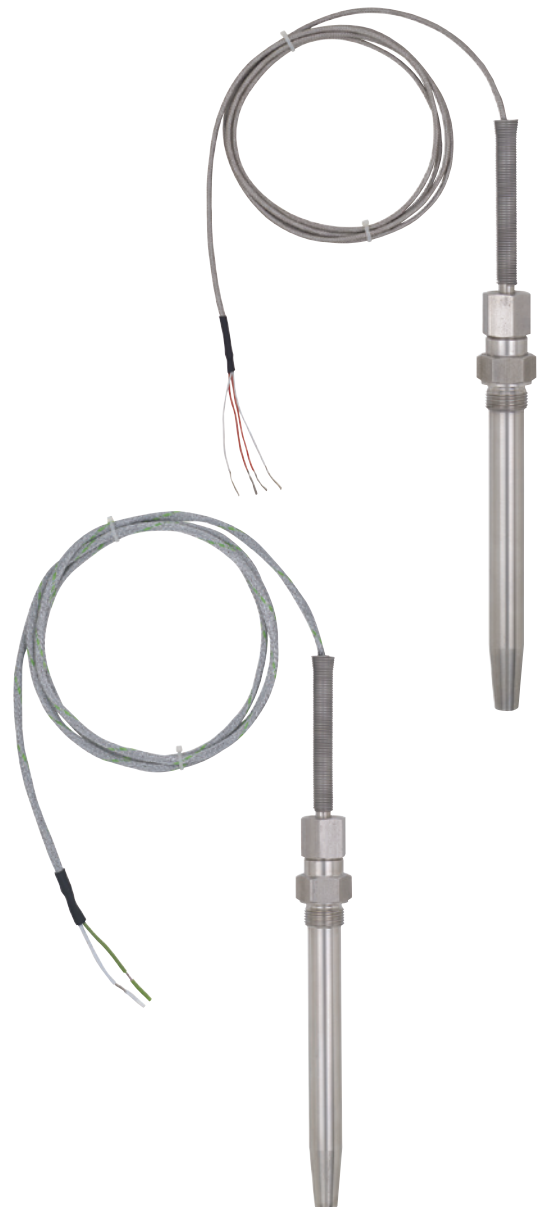

Fig. above: Cable Resistance Thermometer Model TR192
Fig. below: Cable Thermocouple Model TC192

Sensor Thermocouples with Model TC192

Type

- K (NiCr-Ni) application range up to 850 °C
- J (Fe-CuNi) application range up to 600 °C

Available as simplex thermocouple. The hot junction of the probe is supplied ungrounded.

Sensor limited error

A cold junction temperature of 0 °C is taken as basis with the definition of the sensor limited error of thermocouples.

Type K DIN EN 60 584 part 2

Class	Temperature range	Limited error
2	-40 °C ... +333 °C	± 2.5 °C
2	+333 °C ... +1200 °C	± 0.0075 · t ¹⁾

1) |t| is the value of the temperature in °C without consideration of the sign

Typ J DIN EN 60 584 Teil 2

Class	Temperature range	Limited error
2	-40 °C ... +333 °C	± 2.5 °C
2	+333 °C ... +750 °C	± 0.0075 · t ¹⁾

1) |t| is the value of the temperature in °C without consideration of the sign

Limited error with selected temperatures in °C

Temperature (ITS 90) °C	Limited error DIN EN 60 584 class 2	
	Type K °C	Type J °C
0	± 2.5	± 2.5
200	± 2.5	± 2.5
400	± 3	± 3
600	± 4.5	± 4.5
800	± 6	not defined

Sensor Pt100 with Model TR192

Sensor limited error

- Class B per DIN EN 60 751

Basic values and limiting errors

Basic values and limiting errors for the platinum measurement resistances are laid down in DIN EN 60 751.

The nominal value of Pt 100 sensors is 100 Ω at 0 °C.

The temperature coefficient α can be stated simply to be between 0 °C and 100 °C with:

$$\alpha = 3.85 \cdot 10^{-3} \text{ °C}^{-1}$$

The relationship between the temperature and the electrical resistance is characterised by polynomials which are defined in DIN EN 60 751. Furthermore, this standard lays down the basic values in °C stages.

Class	Limited error in °C
A	0.15 + 0.002 · t ¹⁾
B	0.3 + 0.005 · t

1) |t| is the value of the temperature in °C without consideration of the sign

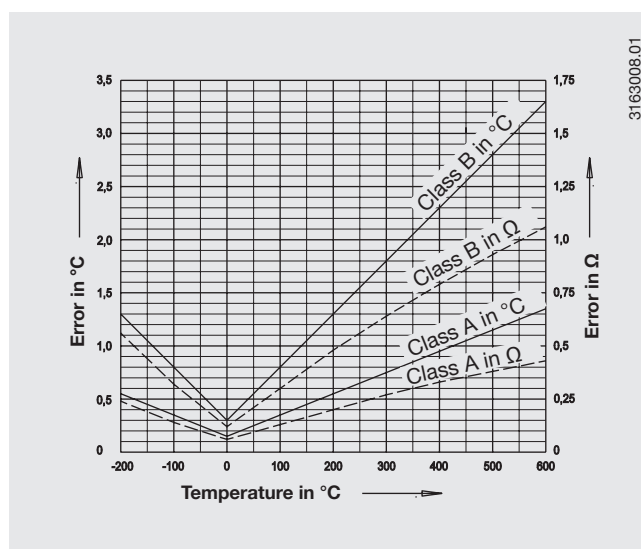

Temperature (ITS 90) °C	Basic value Ω	Limiting error DIN EN 60 751			
		Class A °C		Class B °C	
0	100	± 0.15	± 0.06	± 0.3	± 0.12
100	138.51	± 0.35	± 0.13	± 0.8	± 0.30
200	175.86	± 0.55	± 0.20	± 1.3	± 0.48
400	247.09	± 0.95	± 0.33	± 2.3	± 0.79
600	313.71	± 1.35	± 0.43	± 3.3	± 1.06

Process connection

Model TC192 and Model TR192

Connection design: Male thread
Material: Stainless steel 1.4571
Thread: G ½ B, G ¾ B or M18 x 1.5
other versions on request

Thermowell

Model TC192 and Model TR192

Design: of bar stock
Material: Stainless steel 1.4571
Diameter: 15 mm, tapered to 12 mm
18 mm, tapered to 12 mm
22 mm, tapered to 15 mm
Insertion length: 100 mm, 120 mm, 150 mm, 160 mm,
200 mm, 250 mm
other versions on request

Cable

Model TC192

Isulation: Silicone-glass filament
Armour: Steel braid, zinc galvanized
Cable relief: Spring
Permissible ambient temperature: -50 °C ... +200 °C
Core material: Compensating cable according to type
of sensor (lead)
Core cross section: 1.5 mm²
Number of cores: 2
Wire ends: blank / end sleeve / cable shoe
(option)
Cable length: to customer's specification

Model TR192

Isulation: PTFE- glass filament
Armour: Steel braid, zinc galvanized
Cable relief: Spring
Permissible ambient temperature: -200 °C ... +250 °C
Core material: Cu (lead)
Core cross section: 0.5 mm²
Number of cores: 4
Wire ends: blank / end sleeve / cable shoe
(option)
Cable length: to customer's specification

Cable probes with field case (option)

Model TC192 and Model TR192

Material: Aluminium, epoxy coated
Cap: Detachable, 2 fixing screws,
EPDM flat seal
Cable glands: Pg 16
Ingress protection: IP 67
Terminal block: Ceramic, max. 1.5 mm²,
screws captive
Ground terminal: included

Transmitter (option)

Model TR192

An optional transmitter can be mounted in the junctionbox.
The T24 is available with a separate GL-approval.

Dimensions in mm

Model TC192 and TR192

3376066.01

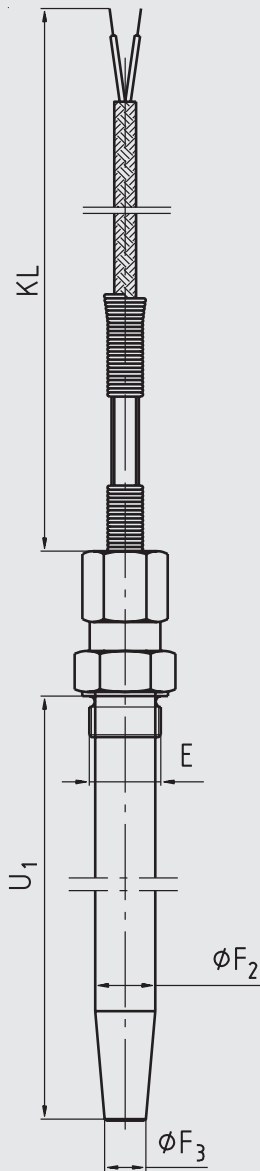

Legend:

- E Thread
- KL Cable length
- U₁ Insertion length
- Ø F₂ Thermowell outer diameter
- Ø F₃ Thermowell outer diameter, tapered

Field case

3381000.01

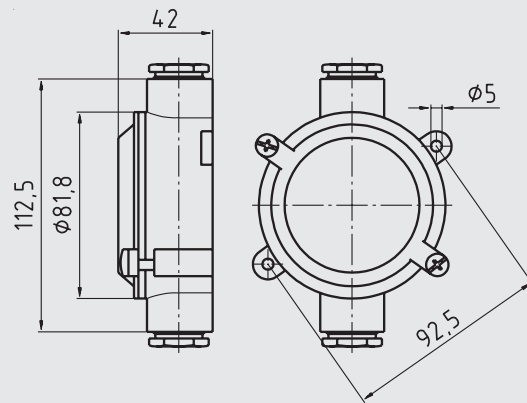

Electrical connection

Model TC192 with cable

Sensor Type K

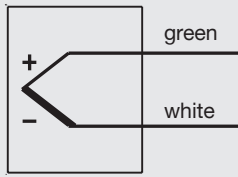

Sensor Type J

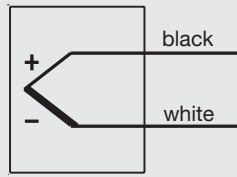

3171966.01

Model TR192 with cable

1 x Pt100
2-wire

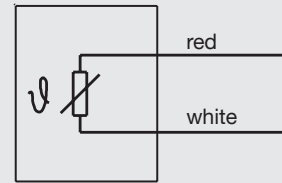

1 x Pt100
3-wire

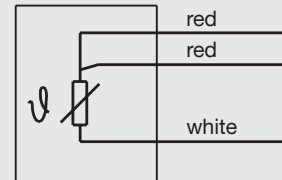

1 x Pt100
4-wire

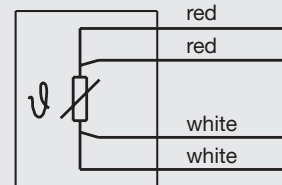

3160696.01

Model TC192 with terminal block in field case

Sensor Type K

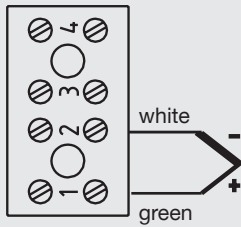

Sensor Type J

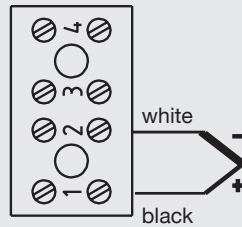

3376695.03

Model TR192 with terminal block in field case

1 x Pt100
2-wire

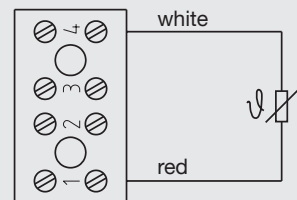

1 x Pt100
3-wire

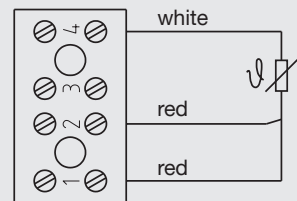

1 x Pt100
4-wire

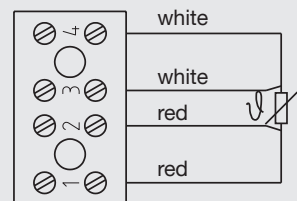

3376695.03

Modifications may take place and materials specified may be replaced by others without prior notice.
Specifications and dimensions given in this leaflet represent the state of engineering at the time of printing.



WIKA Alexander Wiegand GmbH & Co. KG
Alexander-Wiegand-Straße 30
63911 Klingenberg/Germany
Tel. (+49) 9372/132-0
Fax (+49) 9372/132-406
E-mail info@wika.de
www.wika.de