

Electronic temperature switch with display Model TR70

WIKA data sheet TE 67.02

Applications

- Machine building
- General applications

Special features

- Rotatable digital display
- 2 switching outputs
- Freely programmable
- Stainless steel case IP 65
- Optional active 3-wire 4 ... 20 mA output

Description

The model TR70 temperature switch measures process temperatures, indicates measured values and provides control signals as well as analogue signals. These temperature switches have been designed for direct installation into the process. An additional thermowell is not provided in the standard version.

Simple operation

A robust and compact design, combined with ease of handling, are the key features of this state-of-the-art temperature switch. The innovative shape, with its large, angled display, able to rotate through 330°, enables the user to see the measured value from various directions, even under difficult lighting conditions or from a distance. The measurement units, switch points, as well as start and end value of the analogue output can be configured easily.

Proven measuring technologies

For decades WIKA sensors have guaranteed high accuracy, long-term stability and repeatability in industrial temperature measurement.



Temperature switch model TR70 with connecting cable (option)

The TR70 provides the user with an instrument with excellent switching functionality. It is ideally suited for long-term use in both OEM and industrial applications.

Comprehensive functionality

This model series combines the functions of a temperature switch, a digital display and a temperature transmitter - equipped with two independently configurable switching outputs, a temperature display as well as an optional analogue output.

Versatile

Together with a large indication range, very wide working ranges are given. Equally flexible, the installation details such as process thread, stem length and stem diameter can be adapted to the respective conditions.

Specifications

General information	
Display	4-digit 8-segment LED display, red, height: 7.6 mm, with protective foil
Indication ranges	-50 ... +200 °C (standard) 0 ... +400 °C, 0 ... +600 °C, -200 ... +600 °C
Electrical connection	M12 x 1, 4-pin plug with gold-plated contacts
Switching function	NO/NC programmable
Version variants	■ 2 switching outputs ■ 1 switching output + 1 analogue output 4 ... 20 mA
Output functions	DC PNP
Analogue output	4 ... 20 mA, max. load 700 Ω at DC 24 V
Power supply	DC 12 ... 30 V
Maximum current	100 mA
Reverse polarity protection, overpressure safety	yes
Voltage drop	< 2 V
Current supply	< 65 mA
Start up delay	2 sec
Measure, display cycle	1/sec

Probe	
Sensor	1 x Pt100, class B per DIN EN 60751
Insertion length A	■ With threaded connection 25, 50, 75, 100, 160, 300, 400 and 500 mm ■ With compression fitting 100, 200, 300, 400 and 500 mm
Probe diameter	■ Ø 6 x 0.75 mm from insertion length 50 mm, max. pressure 40 bar (standard) ■ Ø 8 x 1.75 mm from 50 mm insertion length, max. pressure 100 bar ■ Ø 3 x 0.25 mm, insertion length 25 mm Fast response special version with tapered tip, max. pressure 12 bar ■ Insertion length 50 to 100 mm: Ø 6 x 0.25 mm tapered to Ø 3 x 0.25 mm ■ From insertion length 100 mm: Ø 8 x 1.75 mm tapered to Ø 6 x 0.25 mm tapered to Ø 3 x 0.25 mm
Response times	■ Ø 3 mm: t ₅₀ = 3 s t ₉₀ = 9 s ■ Ø 6 mm: t ₅₀ = 10 s t ₉₀ = 32 s ■ Ø 8 mm: t ₅₀ = 20 s t ₉₀ = 68 s
Process connections	Threaded connection or sliding compression fitting: G ½ B, G ¾ B, G ¼ B, ½ NPT, ¼ NPT

Setting range	
Switch point	-49.5 ... 200.0 °C in increments of 0.5 °C
Reset point	-50.0 ... 199.5 °C in increments of 0.5 °C
Unit	°C or °F (adjustable)

Resolution	
Switching output	0.5 °C
Analogue output	0.1 °C
Display	0.1 °C
Temperature effect	0.1 K per 10 K

Ambient conditions	
Ambient temperature	-25 ... +70 °C
Storage temperature	-30 ... +80 °C
Ingress protection	IP 65 per IEC 529
Insulation resistance	100 MΩ / DC 500 V
Electromagnetic compatibility (EMC) per IEC / EN 61326	IEC 61000-4-2 ESD: B IEC 61000-4-3 HF radiated: A IEC 61000-4-4 Burst: A IEC 61000-4-5 Surge: A IEC 61000-4-6 HF line borne: A

Dimensions in mm

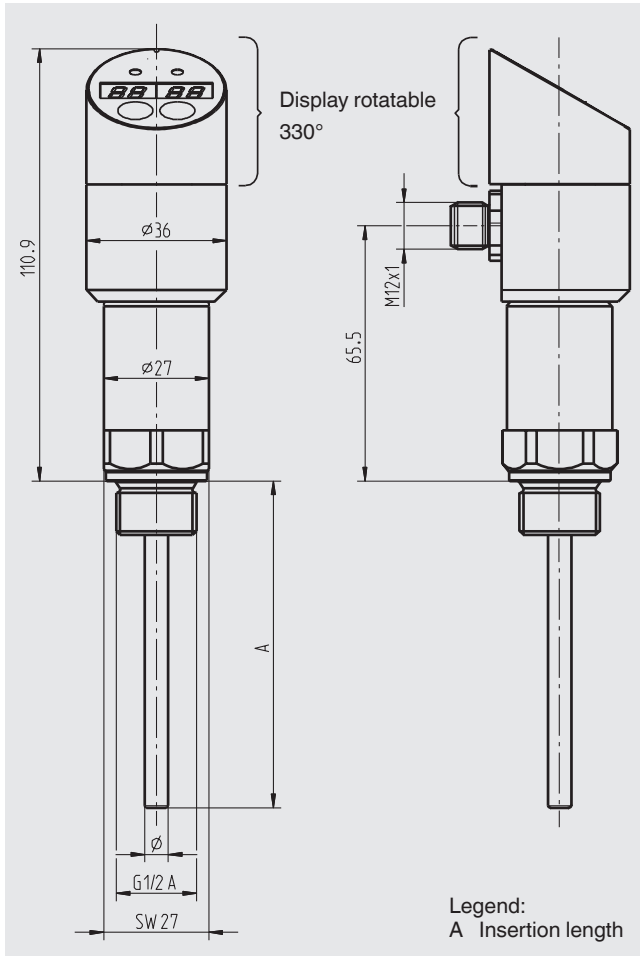

With media temperatures greater than 125 °C, we recommend the use of the variant with an neck tube or with a compression fitting.

For the 400 °C design, the minimum neck tube length is 50 mm and for the 600 °C design the minimum neck tube length is 100 mm.

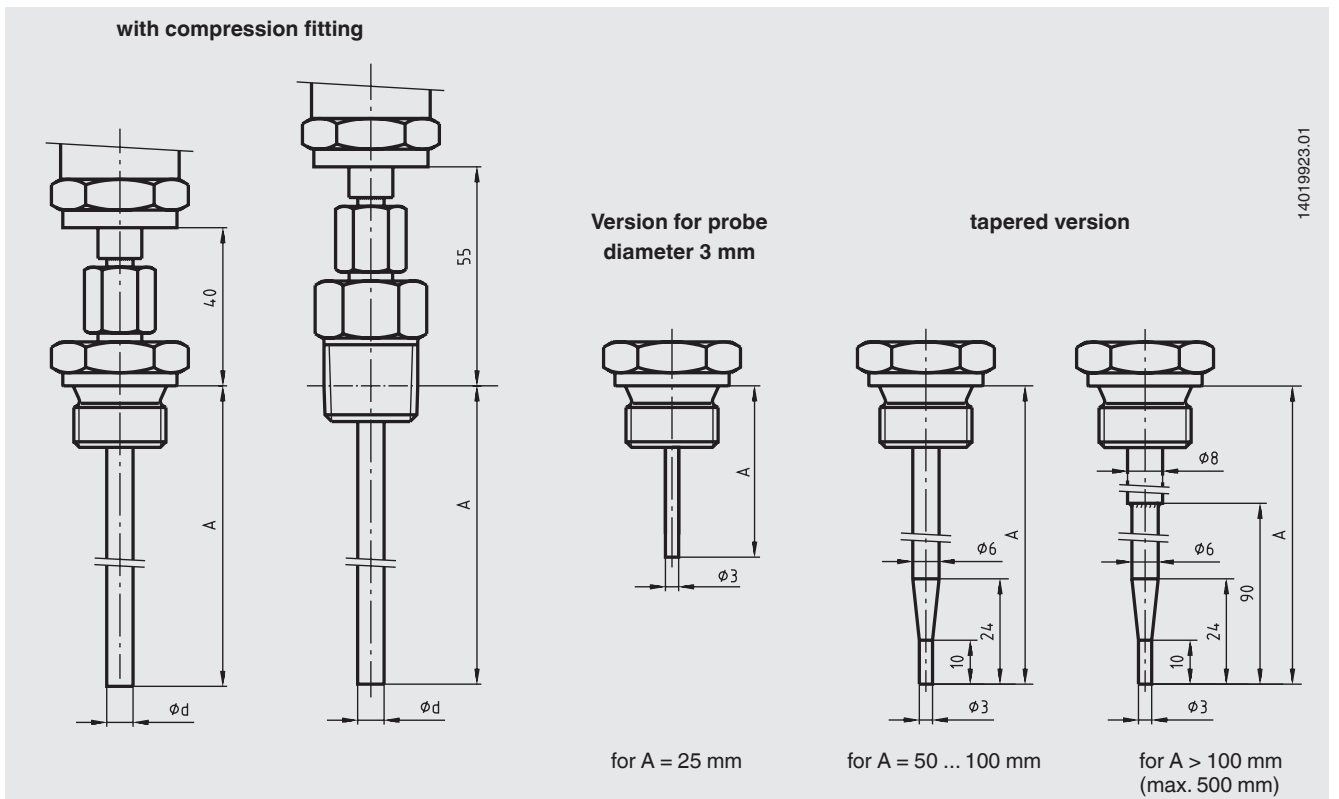

Electrical connection

M12 x 1, 4-pin (Pin 2 = analogue output as pictured or switching output S2)

1 switching output and 1 analogue output

2 switching outputs

p-switching:

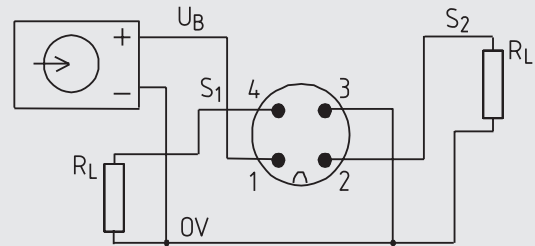
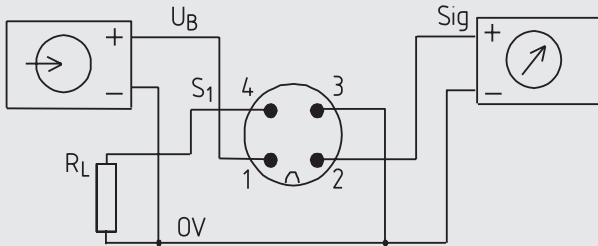

Connector

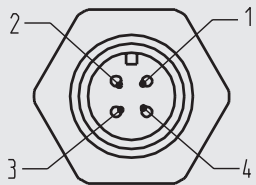

Signal	Connector
Supply U_B	1
Supply 0 V	3
Switching output 1	4
Switching output 2 or analogue output	2

Ordering information

Model / Switching or analogue output / Threaded version / Thread size / Probe diameter / Indication range / Insertion length A / Certificates

© 2007 WIKA Alexander Wiegand SE & Co. KG, all rights reserved.
The specifications given in this document represent the state of engineering at the time of publishing.
We reserve the right to make modifications to the specifications and materials.



WIKAL Alexander Wiegand SE & Co. KG
Alexander-Wiegand-Straße 30
63911 Klingenberg/Germany
Tel. (+49) 9372/132-0
Fax (+49) 9372/132-406
E-mail info@wika.de
www.wika.de