

## Cable thermocouple Model TC40

WIKA data sheet TE 65.40



### Applications

- For direct installation into the process
- Machine building
- Motors
- Bearings
- Pipelines and vessels

### Special features

- Application ranges from 0 ... +1200 °C
- For insertion, screw-in with optional process connection
- Cable from PVC, silicone, PTFE or glass fibre
- Explosion-protected versions Ex-i, Ex-n and NAMUR NE24
- High mechanical strength



Cable thermocouple model TC40

### Description

Cable thermocouples are particularly suited to those applications in which the metallic sensor tip is mounted directly into bored holes (e.g. in machine components) or directly into the process for any application with no chemically aggressive media or abrasion.

For mounting into a thermowell, a spring-loaded compression fitting should be provided, since only this can press the sensor tip into the bottom of the thermowell. Otherwise a potentially critical force could be exerted on the measuring tip.

In the standard version the cable sensors are manufactured without process connections. Fastening elements such as threaded fittings, union nuts, etc. can also be used.

# Sensor

## Sensor type

Model	Recommended max. operating temperature
K (NiCr-Ni)	1200 °C
J (Fe-CuNi)	800 °C
E (NiCr-CuNi)	800 °C
T (Cu-CuNi)	400 °C
N (NiCrSi-NiSi)	1200 °C

The actual application range of these thermometers is limited both by the permissible max. temperature of the thermocouple as well as by the permissible max. temperature of the thermowell material. If the temperature under measurement is higher than the permissible temperature at the cable access point, the distance between the cable transition and the critical temperature has to be adapted accordingly by an increased sensor length.

Listed thermocouples are available both as single or dual thermocouples. The thermocouple will be delivered with an insulated measuring point, unless explicitly specified otherwise.

## Tolerance value

A cold junction temperature of 0 °C is taken as basis with the definition of the tolerance value of thermocouples.

## Type K

Class	Temperature range	Tolerance value
<b>DIN EN 60584 part 2</b>		
1	-40 ... +375 °C	± 1.5 °C
1	+375 ... +1000 °C	± 0.0040 •  t  <sup>1)</sup>
2	-40 ... +333 °C	± 2.5 °C
2	+333 ... +1200 °C	± 0.0075 •  t  <sup>1)</sup>
<b>ISA (ANSI) MC96.1-1982</b>		
Standard	0 ... +1250 °C	± 2.2 °C or <sup>2)</sup> ± 0.75 %
Special	0 ... +1250 °C	± 1.1 °C or <sup>2)</sup> ± 0.4 %

## Type J

Class	Temperature range	Tolerance value
<b>DIN EN 60584 part 2</b>		
1	-40 ... +375 °C	± 1.5 °C
1	+375 ... +750 °C	± 0.0040 •  t  <sup>1)</sup>
2	-40 ... +333 °C	± 2.5 °C
2	+333 ... +750 °C	± 0.0075 •  t  <sup>1)</sup>
<b>ISA (ANSI) MC96.1-1982</b>		
Standard	0 ... +750 °C	± 2.2 °C or <sup>2)</sup> ± 0.75 %
Special	0 ... +750 °C	± 1.1 °C or <sup>2)</sup> ± 0.4 %

## Type E

Class	Temperature range	Tolerance value
<b>DIN EN 60584 part 2</b>		
1	-40 ... +375 °C	± 1.5 °C
1	+375 ... +800 °C	± 0.0040 •  t  <sup>1)</sup>
2	-40 ... +333 °C	± 2.5 °C
2	+333 ... +900 °C	± 0.0075 •  t  <sup>1)</sup>

## Type T

Class	Temperature range	Tolerance value
<b>DIN EN 60584 part 2</b>		
1	-40 ... +125 °C	± 0.5 °C
1	+125 ... +350 °C	± 0.0040 •  t  <sup>1)</sup>
2	-40 ... +133 °C	± 1.0 °C
2	+133 ... +350 °C	± 0.0075 •  t  <sup>1)</sup>

## Type N

Class	Temperature range	Tolerance value
<b>DIN EN 60584 part 2</b>		
1	-40 ... +375 °C	± 1.5 °C
1	+375 ... +1000 °C	± 0.0040 •  t  <sup>1)</sup>
2	-40 ... +333 °C	± 2.5 °C
2	+333 ... +1200 °C	± 0.0075 •  t  <sup>1)</sup>

1) |t| is the value of the temperature in °C irrespective of the sign.

2) Whichever is the greater

Limited error with selected temperatures in °C for thermocouples type K and type J

Temperature (ITS 90) °C	Tolerance value DIN EN 60584 part 2	
	Class 1 °C	Class 2 °C
0	± 1.5	± 2.50
100	± 1.5	± 2.50
200	± 1.5	± 2.50
300	± 1.5	± 2.50
400	± 1.6	± 3.00
500	± 2.0	± 3.75
600	± 2.4	± 4.50
700	± 2.8	± 5.25
800	± 3.2	± 6.00
900	± 3.6	± 6.75
1000	± 4.0	± 7.50
1100	± 4.4	± 8.25
1200	± 4.8	± 9.00

## Potential measuring uncertainties due to ageing effects

Thermocouples are subject to ageing and change their temperature/thermal voltage characteristic. Type J thermocouples of (Fe-Cu-Ni) age slightly due to oxidation of the pure metal leg. In types K and N thermocouples (NiCrSi-NiSi), high temperatures can result in substantial changes to the thermal voltage due to chrome depletion in the NiCr leg, leading to a lower thermal voltage.

This effect is accelerated if there is a shortage of oxygen, since a complete oxide layer, which would protect it from further oxidation, cannot be formed on the surface of the thermocouple. Chromium is oxidised, but nickel isn't. This results in the so-called "**green rot**", destroying the thermocouple. When NiCr-Ni thermocouples that have been operating above 700 °C are cooled quickly, this cooling causes certain states in the crystal structure (**short-range order**) to freeze, which in type K thermocouples can result in a change of the thermal voltage of up to 0.8 mV (K effect).

In Type N thermocouple (NiCrSi-NiSi), it has been possible to reduce the **short-range-order effect** by alloying both legs with silicon. The effect is reversible and is largely eliminated again by annealing above 700 °C, followed by slow cooling. Thin sheathed thermocouples are particularly sensitive. Cooling in still air can even result in deviations of more than 1 K.

## Sensor tip design

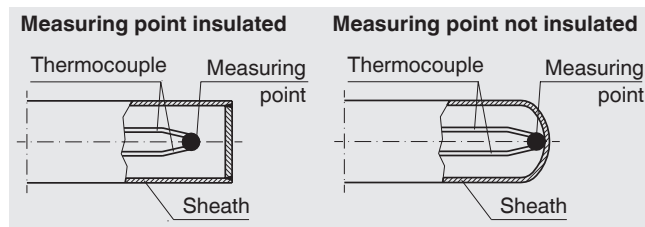

For temperature measurement in a solid body, the diameter of the bore into in which the sensor should be inserted, should be no more than 1 mm larger than the sensor diameter.

**Cable thermocouples can be designed in two different ways:**

### ■ Sheathed design

In sheathed thermocouples the flexible part of the sensor is a mineral-insulated cable (MI-cable).

It consists of a stainless steel outer sheath, which contains the insulated internal leads, embedded within a high-density ceramic compound.

Sheathed thermocouples may be flexed with a radius 3-times of the sheath diameter – except for the transition sheath. Due to this flexibility, sheathed thermocouples can be applied even at points that are difficult to access.

### Sheath diameter:

- 0.5 mm
- 1.0 mm
- 1.5 mm
- 3.0 mm
- 4.5 mm
- 6.0 mm
- 8.0 mm

Others on request

### Please note:

The flexibility of the sheathed thermocouple must be considered, especially when the flow rates are relatively high. Designs in which the process connection is not located directly at the cable transition should be considered critical in applications where vibratory or oscillating stresses occur.

### Sheath material

- Ni-alloy 2.4816 (Inconel 600)
  - up to 1200 °C (air)
  - standard material for applications which require specific corrosion resistance properties under exposure to high temperatures, resistant to induced stress corrosion cracking and pitting in media containing chloride
  - resistant to corrosion caused by aqueous ammonia in all temperatures and concentrations
  - highly resistant to halogens, chlorine, hydrogen chloride
- Stainless steel
  - up to 850 °C (air)
  - good corrosion resistance with aggressive media as well as steam and flue gases in chemical media

Others on request

### ■ Tubular design

The tubular design features a rigid construction to the metal sensor tip; therefore tubular designs must not be bent. Inside the tube, the connection cable leads until near the sensor tip. Therefore tubular cable thermocouples can only be used up to the temperatures specified for the supply line (see operating temperature).

### Tube diameter:

- 4.0 mm
- 4.5 mm
- 6.0 mm
- 8.0 mm

Others on request

## Transitions

The junction between the metal part of the resistance thermometer and the connecting cable or wire is either rolled or potted, depending on the design. This area should not be immersed within the process and must not be bent. Compression fittings should not be attached to the transition. The type and dimensions of the transition depend largely on the combination between input leads and metal sensor and the sealing requirements.

Dimension T denotes the length of the transition.

Criterion	Dimension T in mm	Ø transition in mm
Probe Ø = transition Ø	n/a	identical to probe
Ø 0.5 ... 4.5 mm with crimped transition	45	6
Ø 6 mm with crimped transition	45	7
Ø 8 mm with crimped transition	45	10

### Connecting cable

There are various insulating materials available to suit any particular environmental conditions.

The cable ends can be prepared ready for connection, or as an option, can be fitted with connectors.

### Connection cable (standard)

- Thermocouple, fit to sensor
- Cross section: min. 0,22 mm<sup>2</sup>
- Number of thermocouple: according to method of connection
- Insulation material: PVC, Silikon, PTFE or fibreglass
- Screen (option)

## Operating temperatures

### ■ Connection cable and single wires

At any point on the connection cable, the maximum temperature that may be attained is that for which the connection cable is specified. The thermocouple itself can potentially withstand higher temperatures.

For the common connection wires the following temperature limits apply:

PVC	-20 ... +100 °C
Silicone	-50 ... +200 °C
PTFE	-50 ... +250 °C
Glass fibre	-50 ... +400 °C

### ■ Transitions

The temperature at the transition is further limited by the use of a potted sealing compound. Maximum temperature of the potting compound: 150 °C.

Optionally: 250 °C

(other variants on request)

### ■ Plug

With the option of a connecting plug fitted the maximum permissible temperature at the plug is 85 °C.

### ■ Working temperature

If the temperature to be measured is higher than the permissible temperature at the connection head, the metallic part of the sensor must be long enough to be outside of the hot zone. It should be noted that the lowest of the max. working temperatures for the cable, transition or connector must not be exceeded.

## Ingress Protection

### ■ IP protection

Cable thermocouples can be delivered with up to IP 65 (dependent on cable sheath material and number of wires). With a special design, IP 67 is also possible on request. Connection leads with a glass-fibre sheath cannot be combined with an explosion-proof design.

### ■ Explosion protection (option)

Cable thermocouples of the TC40 series are available with a EC type-examination certificate for "intrinsically safe", Ex-i, ignition protection.

These instruments comply with the requirements of 94/9/EC (ATEX) directive for gas and dust. Manufacturer's declarations in accordance with NAMUR NE24 are also available.

The classification/suitability of the instrument (permissible power  $P_{max}$  as well as the permissible ambient temperature) for the respective category can be seen on the EC type-examination certificate and in the operating instructions.

The internal inductance ( $L_i$ ) and capacitance ( $C_i$ ) for cable probes are found on the product label and they should be taken into account when connecting to an intrinsically-safe power supply.

## Design

Cable thermocouples are classified into the following variants, depending on the nature of their electrical connections:

- With single wires
- With connection cable
- With connector
- Bare wire ends

### Connection with single wires

Cable length 150 mm, other lengths on request, thermo wire  $\varnothing$  0.5 mm, type of compensating cable according to type of sensor, PTFE insulated, number of conductor end couples according to number of sensors, stripped lead wires other versions on request

The dimension A describes the insertion length into the process. The dimension W describes the length of the connecting wires. L stands for the length of the free single wires. The dimension T describes the transition (if present). T always makes up part of the length W or L (see table Page 4).

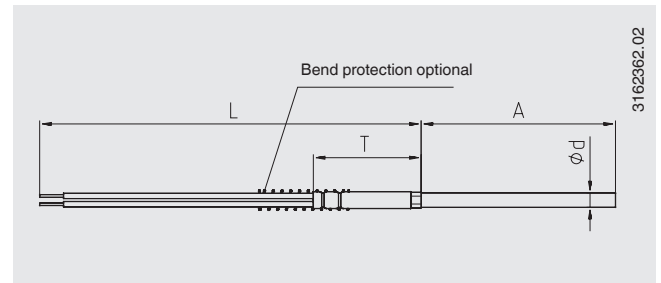

### With connection cable

Cable and sensor are permanently connected to each other. Cable length to user specifications. Compensating cable, leads  $0.22 \text{ mm}^2$ , compensating cable type depending on the sensor type, number of cores according to number of sensors, stripped lead wires

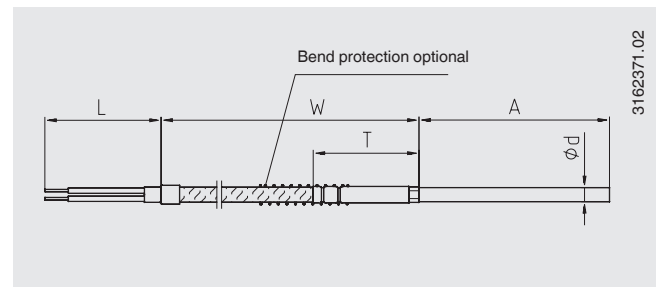

### With connector fitted to connection cable

The optional connection plug is fitted to a flexible connection cable.

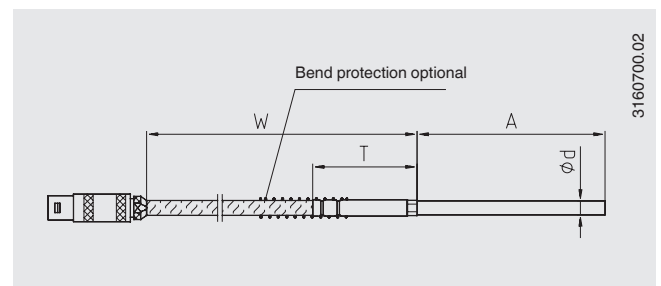

### Designs with bare connecting wires

The internal leads of the mineral-insulated wire protrude. L = 20 mm (standard)

The length of the bare connection wires can be matched to customer requirements. These bare internal leads are made from solid wire, and so are not suitable to be run over long distances.

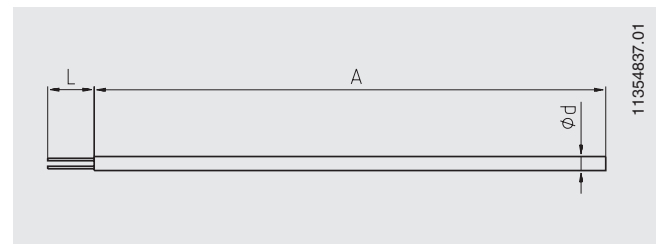

### Design with connector fitted directly to the probe

These designs are based on the design with bare connection wires. The connector is fitted directly to the metallic probe.

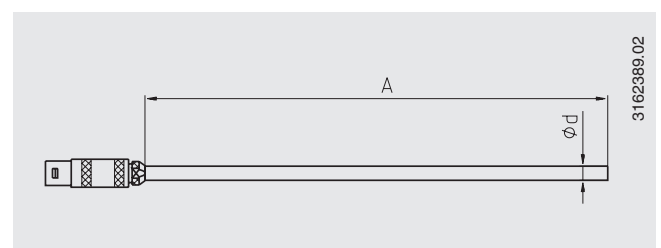

## Process connections for straight probes

The cable thermocouples can be fitted with an optional process connection. The dimension A describes the insertion length into the process.

To minimise heat dissipation errors via the threaded connection, the insertion length, A, should be at least 25 mm long. The position of the threaded connection is specified by the dimension X and is not dependent on the connection type.

### Please note:

- For parallel threads (e.g. G 1/2) the dimensioning always refers to the sealing collar of the threaded connector nearest the process.
- For tapered threads the measurement plane is located approx. in the centre of the thread.

### Fixed threaded connections/threads

used to mount the probe into a threaded coupling with a female thread.

Insertion length A: in accordance with customer specification  
Material: stainless steel, others on request

The sensor must be rotated in order to screw it into the process. Therefore, this design must first be mounted mechanically and it can then be electrically connected.

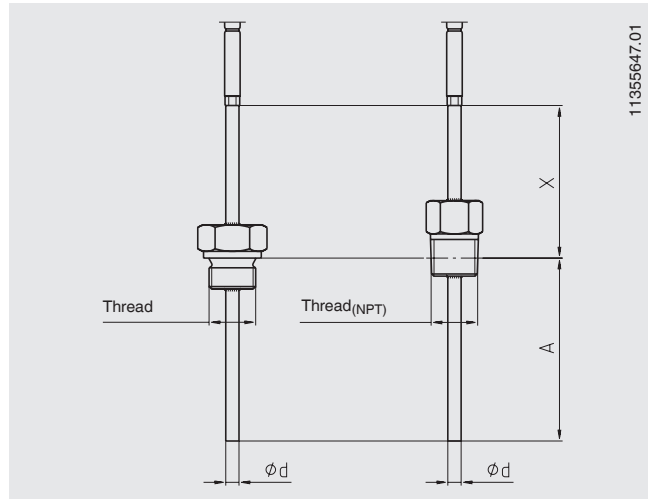

### Compression fitting

allows simple adjustment to the required insertion length at the installation point.

Since the compression fitting is adjustable on the thermowell, the dimensions A and X are stated as the values for the delivered item. The length of the compression fitting determines the smallest possible neck length X of approx. 40 mm.

Material: stainless steel

Sealing ring material: stainless steel or PTFE

Stainless steel sealing rings can be adjusted once; once they have been unscrewed, sliding along the sheath is no longer possible.

- Max. temperature at process connection 500 °C
- Max. pressure load 40 bar

PTFE sealing rings can be adjusted several times, after unscrewing, repeated sliding along the sheath is still possible.

- Max. temperature at process connection 150 °C
- For use without pressure

For sheathed resistance thermometers with a  $\phi$  of 2 mm, only PTFE sealing rings are approved.

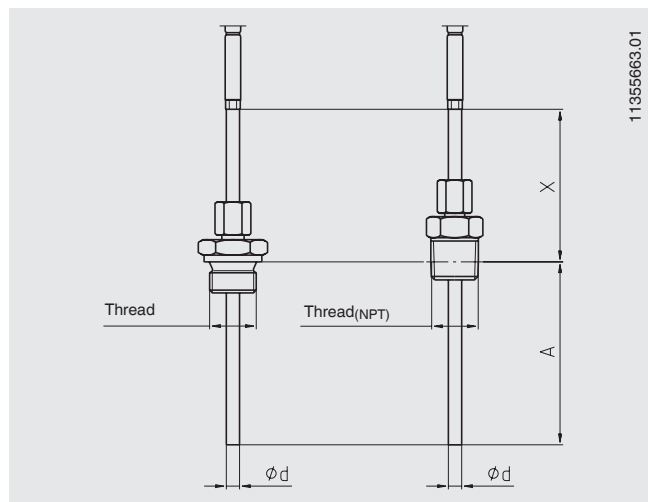

### Spring-loaded compression fitting

allows easy adjustment to the desired insertion length at the mounting point, while at the same time maintaining the spring pre-tension

Since the compression fitting is adjustable on the thermowell, the dimensions A and X are stated as the values for the delivered item. The length of the compression fitting determines the smallest possible neck length X of approx. 80 mm.

Material: stainless steel

Sealing ring material: stainless steel

Stainless steel sealing rings can be adjusted once; once they have been unscrewed, sliding along the sheath is no longer possible.

- Max. temperature at process connection 500 °C

A pressure load on the compression fitting is not intended.

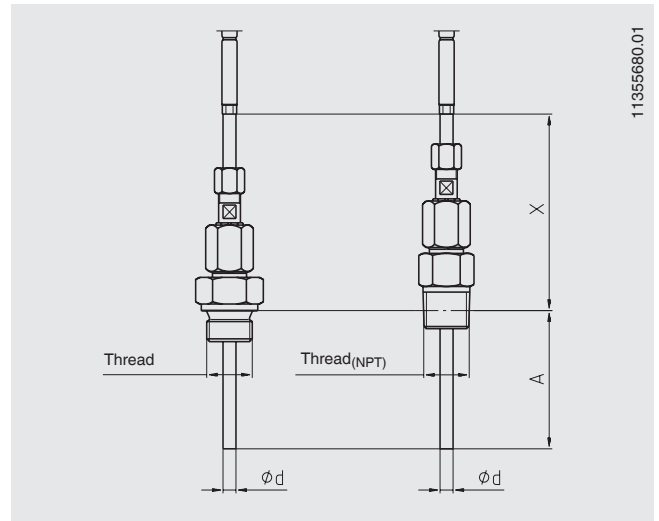

### Union nut (female)

used to mount the probe into a threaded coupling with a male thread.

The probe and threads rotate against each other, so the order in which the mechanical and electrical installation is made is not important.

This option is not advisable for NPT threads.

Insertion length A: in accordance with customer specification

Material: stainless steel, others on request

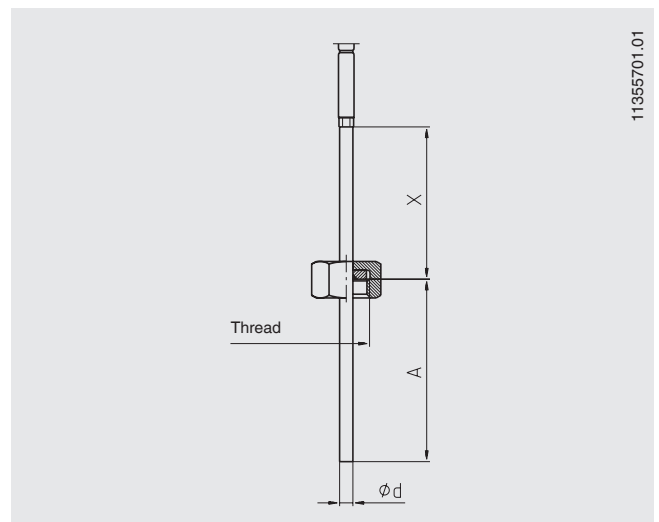

### Male nut

used to mount the probe into a threaded coupling with a female thread.

The probe and threads rotate against each other, so the order in which the mechanical and electrical installation is made is not important.

This option is not advisable for NPT threads.

Insertion length A: in accordance with customer specification

Material: stainless steel, others on request

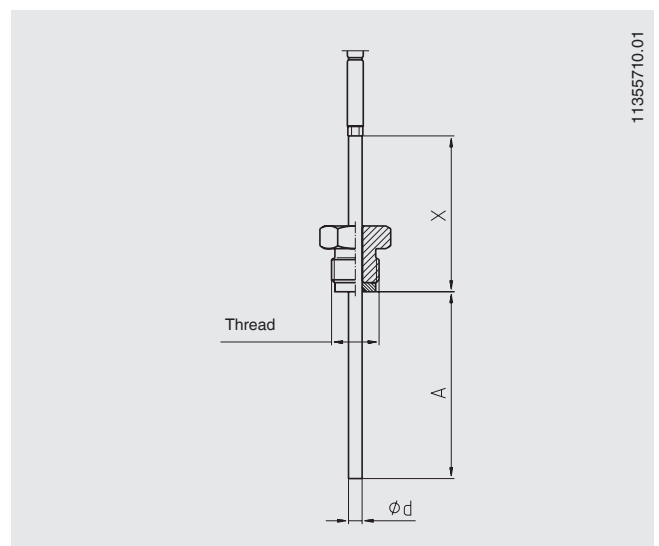

## Angled probes

Cable thermocouples made from sheathed cable can be delivered in a pre-formed shape. In this case, the position of the bend is defined by a further dimension.

The dimension X describes the distance of the bend from the lower edge of the transition.

The dimension A is always the insertion length of the sensor, and thus the area which is built in to the process.

If a threaded connection is used on the bent probe, then the dimension Y describes the distance from the centre of the bend to the measurement plane of the threaded connection.

Using a fixed threaded connection is not recommended, as the bent sensor would need to be screwed into the process with a wide sweeping movement.

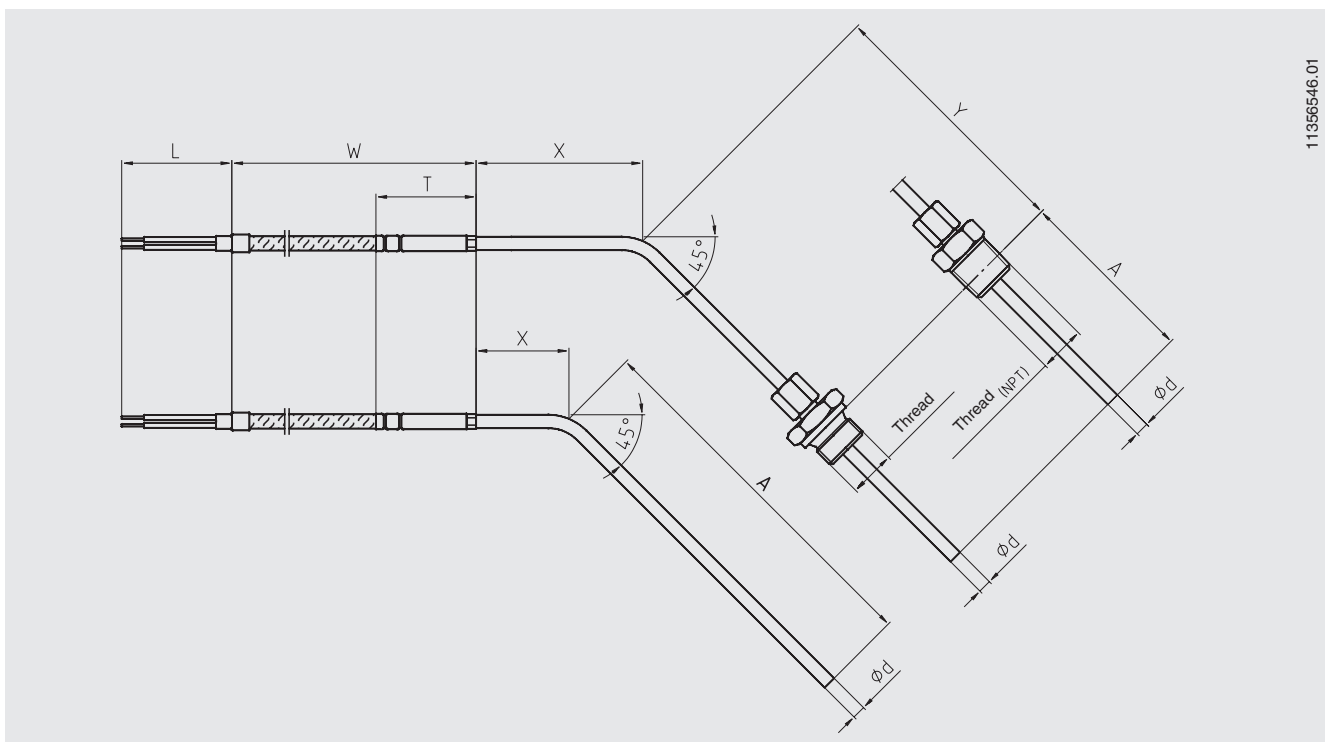
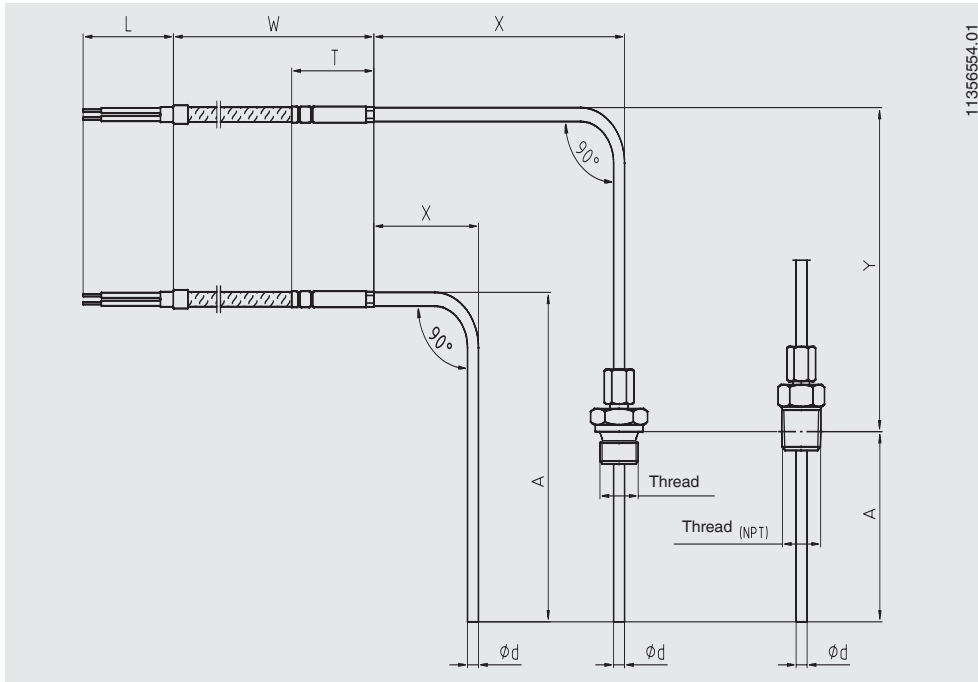

## Plug (option)

Cable thermocouples can be supplied with plugs fitted.

The following options are available:

### ■ Terminal ends

(not suitable for versions with bare connecting wires)

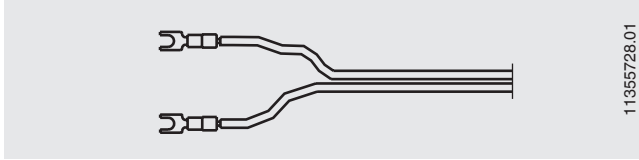

### ■ Screw-in-plug, Binder (male)

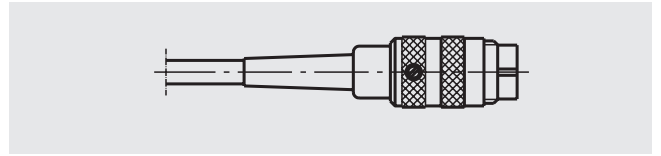

### ■ Lemoso plug size, 1 S (male)

### ■ Lemoso plug size 2 S (male)

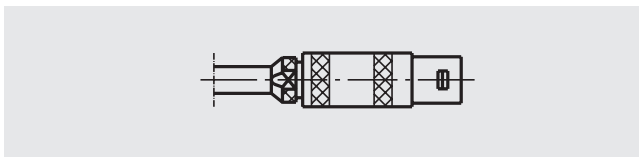

### ■ Screw-in-plug, Binder (female)

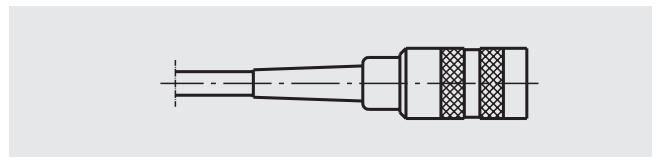

### ■ Lemoso plug, size 1 S (female)

### ■ Lemoso plug, size 2 S (female)

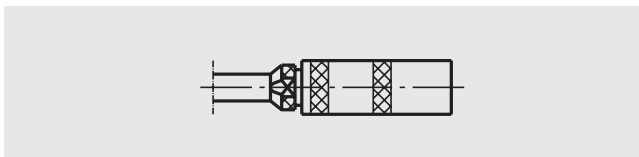

### ■ Standard thermo plug 2-pin (male)

### ■ Miniature thermo plug 2-pin (male)

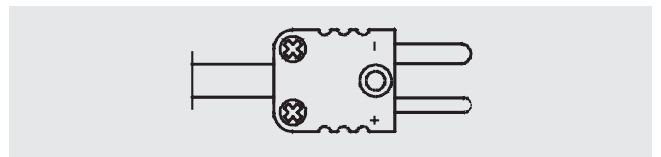

### ■ Standard thermo plug 2-pin (female)

### ■ Miniature thermo plug 2-pin (female)

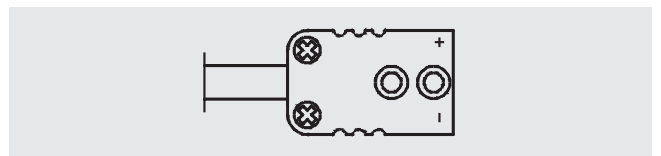

## Further options

### Bend protector

A cable protector (spring or shrink sleeving) is used to protect the transition point from rigid probe to flexible connection cable. This should always be used when a relative movement between the cable and the thermometer mounting is expected.

For designs to Ex-n the use of bend protection is obligatory.

The standard length of the bend protection spring is 60 mm.

### Transition with the same diameter as the probe

Optionally, a transition can also be selected that has the same diameter as the metal probe. This makes it possible to slide on cable glands or compression fittings from both ends of the sensor. The transition is hardly visible.

The operating limits of the transition do not change, however, i.e. they must still remain outside the process and should not be loaded with a compression fitting.

## Electrical connection

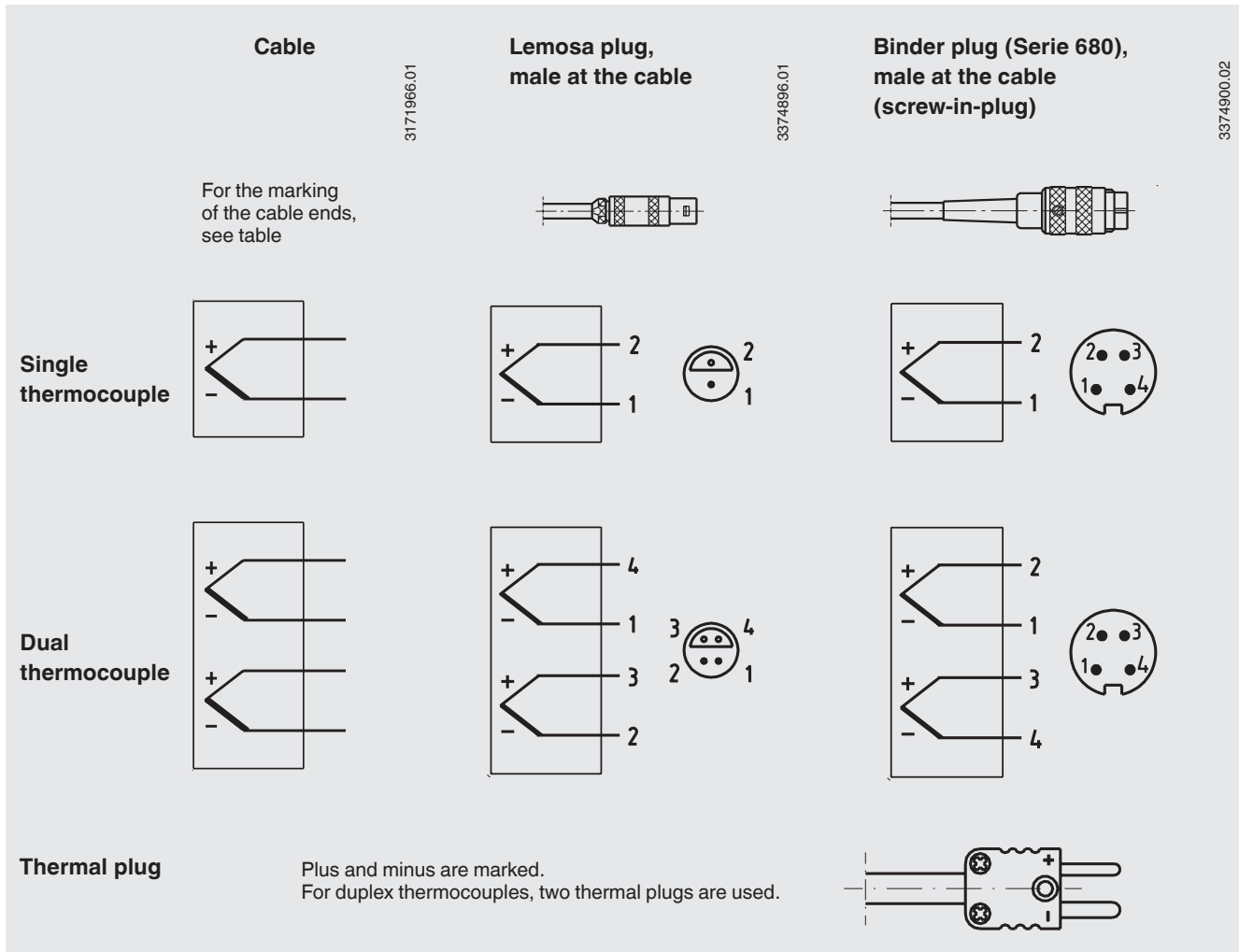

Other connector plugs and other PIN assignments on request.

## Colour code of cable

Sensor type	Standard	Positive	Negative
<b>K</b>	DIN EN 60584	green	white
<b>J</b>	DIN EN 60584	black	white
<b>E</b>	DIN EN 60584	violet	white
<b>T</b>	DIN EN 60584	brown	white
<b>N</b>	DIN EN 60584	pink	white

© 2008 WIKA Alexander Wiegand SE & Co. KG, all rights reserved.  
The specifications given in this document represent the state of engineering at the time of publishing.  
We reserve the right to make modifications to the specifications and materials.

