

## Thermocouple Model TC10-E, for additional thermowell

WIKA data sheet TE 65.05



### Applications

- Chemical industry
- Petrochemical industry
- Offshore
- Machine building, plant and vessel construction
- Energy and power plant technology

### Special features

- For many variants of temperature transmitters with displays
- For mounting in all standard thermowell designs
- Spring-loaded measuring insert (not replaceable)
- Explosion-protected versions Ex i, Ex n and NAMUR NE24

### Description

Thermocouples in this series can be combined with a large number of thermowell designs. Operation without thermowell is only recommended in certain applications.

A wide variety of possible combinations of sensor, connection head, insertion length, neck length, connection to thermowell etc. are available for the thermometers; suitable for any thermowell dimension and any application.



Thermoelement for additional thermowell,  
model TC10-E

# Sensor

## Sensor type

Model	Recommended max. operating temperature
K (NiCr-Ni)	1,200 °C
J (Fe-CuNi)	800 °C
E (NiCr-CuNi)	800 °C
T (Cu-CuNi)	400 °C
N (NiCrSi-NiSi)	1,200 °C

The actual application range of these thermometers is limited both by the permissible max. temperature of the thermocouple and the sheath material as well as by the permissible max. temperature of the thermowell material.

Listed thermocouples are available both as single or dual thermocouples. The thermocouple will be delivered with an insulated measuring point, unless explicitly specified otherwise.

## Tolerance value

For the tolerance value of thermocouples, a cold junction temperature of 0 °C has been taken as the basis.

## Type K

Class	Temperature range	Tolerance value
<b>DIN EN 60584 part 2</b>		
1	-40 ... +375 °C	±1.5 °C
1	+375 ... +1,000 °C	±0.0040 ·  t  <sup>1)</sup>
2	-40 ... +333 °C	±2.5 °C
2	+333 ... +1,200 °C	±0.0075 ·  t  <sup>1)</sup>
<b>ISA (ANSI) MC96.1-1982</b>		
Standard	0 ... +1,250 °C	±2.2 °C or <sup>2)</sup> ±0.75 %
Special	0 ... +1,250 °C	±1.1 °C or <sup>2)</sup> ±0.4 %

## Type J

Class	Temperature range	Tolerance value
<b>DIN EN 60584 part 2</b>		
1	-40 ... +375 °C	±1.5 °C
1	+375 ... +750 °C	±0.0040 ·  t  <sup>1)</sup>
2	-40 ... +333 °C	±2.5 °C
2	+333 ... +750 °C	±0.0075 ·  t  <sup>1)</sup>
<b>ISA (ANSI) MC96.1-1982</b>		
Standard	0 ... +750 °C	±2.2 °C or <sup>2)</sup> ±0.75 %
Special	0 ... +750 °C	±1.1 °C or <sup>2)</sup> ±0.4 %

## Type E

Class	Temperature range	Tolerance value
<b>DIN EN 60584 part 2</b>		
1	-40 ... +375 °C	±1.5 °C
1	+375 ... +800 °C	±0.0040 ·  t  <sup>1)</sup>
2	-40 ... +333 °C	±2.5 °C
2	+333 ... +900 °C	±0.0075 ·  t  <sup>1)</sup>

## Type T

Class	Temperature range	Tolerance value
<b>DIN EN 60584 part 2</b>		
1	-40 ... +125 °C	±0.5 °C
1	+125 ... +350 °C	±0.0040 ·  t  <sup>1)</sup>
2	-40 ... +133 °C	±1.0 °C
2	+133 ... +350 °C	±0.0075 ·  t  <sup>1)</sup>

## Type N

Class	Temperature range	Tolerance value
<b>DIN EN 60584 part 2</b>		
1	-40 ... +375 °C	±1.5 °C
1	+375 ... +1,000 °C	±0.0040 ·  t  <sup>1)</sup>
2	-40 ... +333 °C	±2.5 °C
2	+333 ... +1,200 °C	±0.0075 ·  t  <sup>1)</sup>

1) |t| is the value of the temperature in °C irrespective of the sign  
2) Whichever is the greater

Limited error with selected temperatures in °C for thermocouples types K and J

Temperature (ITS 90) °C	Tolerance value DIN EN 60584 part 2	
	Class 1 °C	Class 2 °C
0	±1.5	±2.50
100	±1.5	±2.50
200	±1.5	±2.50
300	±1.5	±2.50
400	±1.6	±3.00
500	±2.0	±3.75
600	±2.4	±4.50
700	±2.8	±5.25
800	±3.2	±6.00
900	±3.6	±6.75
1,000	±4.0	±7.50
1,100	±4.4	±8.25
1,200	±4.8	±9.00

## Potential measuring uncertainties due to ageing effects

Thermocouples are subject to ageing and change their temperature/thermal voltage characteristic. Type J thermocouples of (Fe-CuNi) age slightly due to oxidation of the pure metal leg. In types K and N thermocouples (NiCrSi-NiSi), high temperatures can result in substantial changes to the thermal voltage due to chrome depletion in the NiCr leg, leading to a lower thermal voltage.

This effect is accelerated if there is a shortage of oxygen, since a complete oxide layer, which would protect it from further oxidation, cannot be formed on the surface of the thermocouple. Chromium is oxidised, but nickel isn't. This results in the so-called "**green rot**", destroying the thermocouple. When NiCr-Ni thermocouples that have been operating above 700 °C are cooled quickly, this cooling causes certain states in the crystal structure (**short-range order**) to freeze, which in type K thermocouples can result in a change of the thermal voltage of up to 0.8 mV (K effect).

In Type N thermocouple (NiCrSi-NiSi), it has been possible to reduce the **short-range-order effect** by alloying both legs with silicon. The effect is reversible and is largely eliminated again by annealing above 700 °C, followed by slow cooling. Thin sheathed thermocouples are particularly sensitive. Cooling in still air can even result in deviations of more than 1 K.

## Measuring insert

The measuring insert is made of a vibration-resistant, sheathed, mineral-insulated cable (MI cable).

The diameter of the measuring insert should be approx. 1 mm smaller than the bore diameter of the thermowell.

Gaps of more than 0.5 mm between thermowell and the measuring insert will have a negative effect on the heat transfer, and they will result in unfavourable response behaviour from the thermometer.

When fitting the measuring insert into a thermowell, it is very important to determine the correct insertion length (= thermowell length for bottom thicknesses of  $\leq 5.5$  mm). In order to ensure that the measuring insert is firmly pressed down onto the bottom of the thermowell, the insert must be spring-loaded (spring travel: 0 ... 19 mm).

## Neck tube

The neck tube is screwed into the connection head or the case. Connection to head:  $\frac{1}{2}$  NPT, M20 x 1.5 or M24 x 1.5

The neck length depends on the intended use. Usually an isolation is bridged by the neck tube. Also, in many cases, the neck tube serves as a cooling extension between the connection head and the medium, in order to protect any possible built-in transmitter from high medium temperatures.

The standard material for neck tubes is stainless steel.

## Components model TC10-E

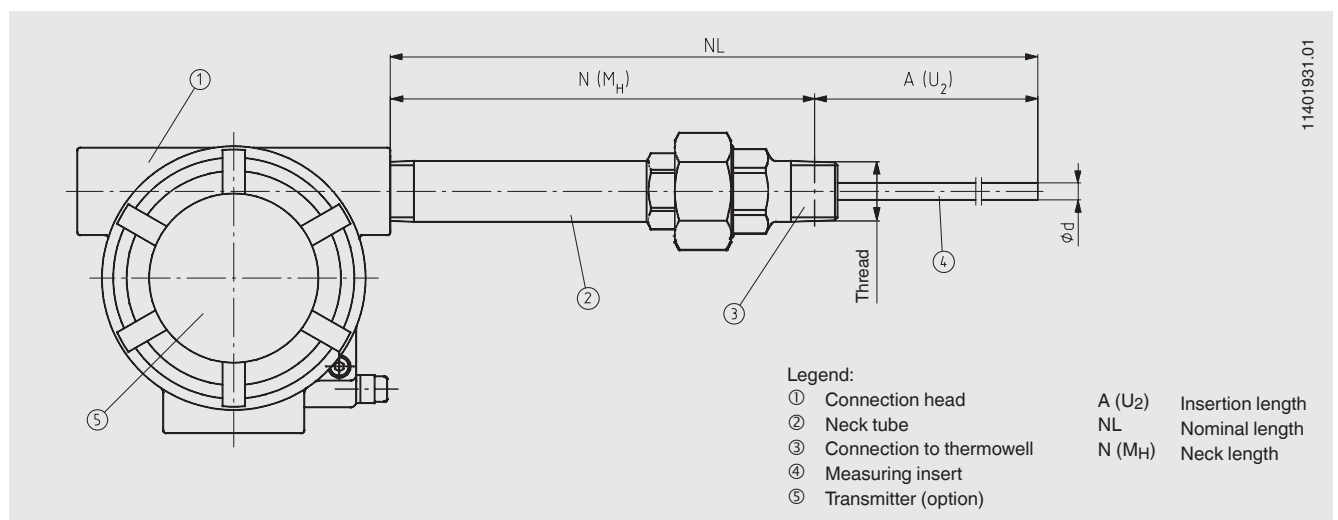

## Connection to thermowell

The many possible designs ensure that the thermocouples, model TC10-E, can be combined with almost all feasible thermowells.

The most usual designs of connection are shown in the following drawings; further connections on request.

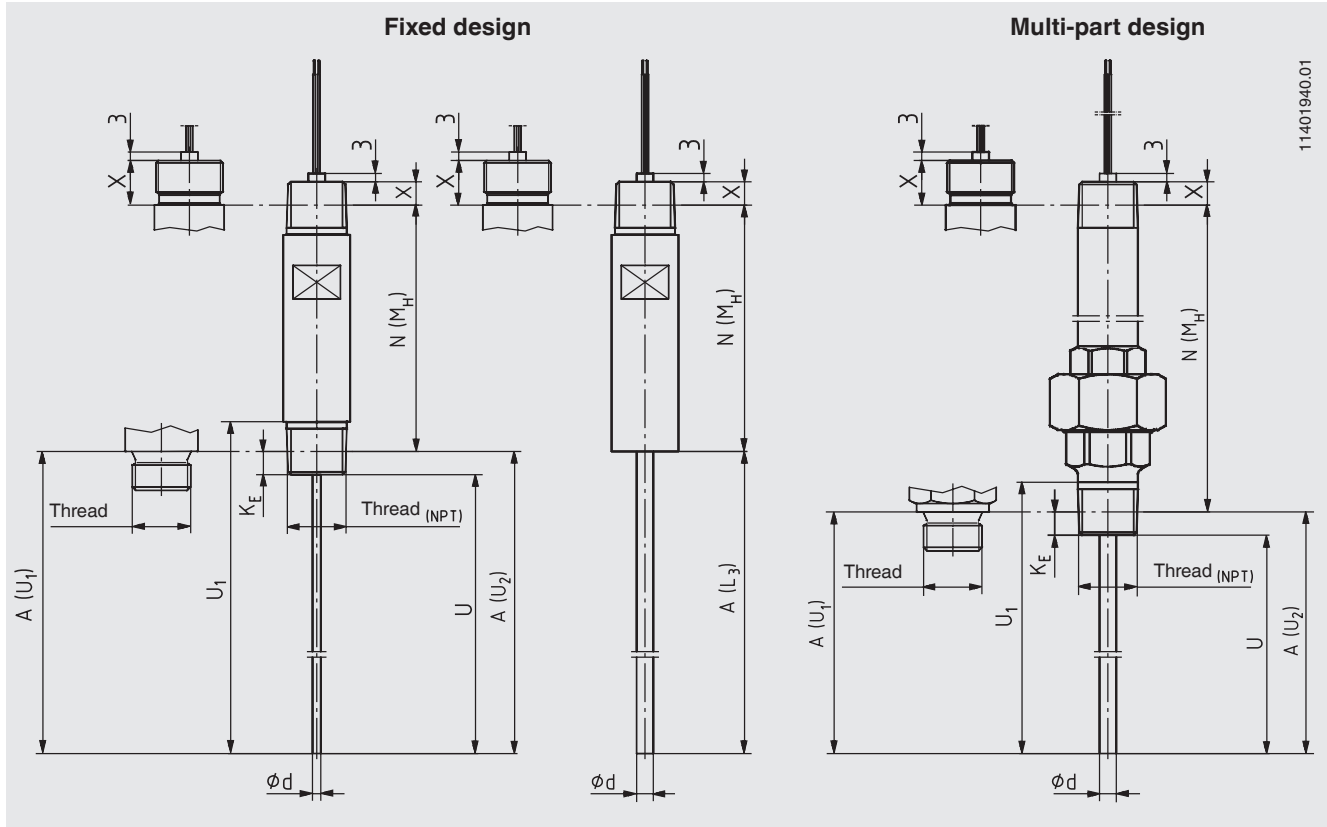

11401940.01

### Possible thread sizes of the male thread at the neck tube

Thread to the thermowell
G 1/2 B
G 3/4 B
M14 x 1.5
M18 x 1.5
1/2 NPT
3/4 NPT

Connection thread to the head	X
1/2 NPT	8 mm
M20 x 1.5	14 mm
M24 x 1.5	16 mm

## Connection head

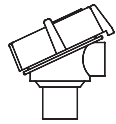

1000/4000

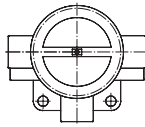

5000/6000

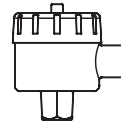

7000/8000

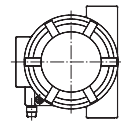

other connection housings

Model	Material	Cable outlet	Ingress protection	Cap	Surface finish
1000/4000	Aluminium	½ NPT, ¾ NPT or M20 x 1.5	IP 65	Screw cover	blue, painted <sup>1)</sup>
1000/4000	Stainless steel	½ NPT, ¾ NPT or M20 x 1.5	IP 65	Screw cover	blank
5000/6000	Aluminium	½ NPT, ¾ NPT or M20 x 1.5	IP 65	Screw cover	blue, painted <sup>1)</sup>
7000/8000	Aluminium	½ NPT, ¾ NPT or M20 x 1.5	IP 65	Screw cover	blue, painted <sup>1)</sup>
7000/8000	Stainless steel	½ NPT, ¾ NPT or M20 x 1.5	IP 65	Screw cover	blank

1) RAL5022

## Field temperature transmitter with digital display (option)

### Field transmitter model TIF50

As an alternative to the standard connection head the thermometer can be fitted with an optional model TIF50 field temperature transmitter.

The field temperature transmitter comprises a 4 ... 20 mA/ HART® protocol output and is equipped with an LCD indication module.



Field temperature transmitter model TIF50

## Transmitter (option)

As an option, WIKA analogue or digital transmitters can be installed in the TC10-E connection head.

Matching the certification of the installed transmitter to the explosion protection of the sensor is necessary.

Model	Description	Explosion protection	Data sheet
T12	Digital transmitter, PC configurable	optional	TE 12.03
T32	Digital transmitter, HART® protocol	optional	TE 32.04
T53	Digital transmitter FOUNDATION™ Fieldbus and PROFIBUS® PA	Standard	TE 53.01
TIF50	Digital field temperature transmitter, HART® protocol	optional	TE 62.01

Further transmitters on request.

## Explosion protection

Thermocouples of the TC10-E series are available with a EC type-examination certificate for "intrinsically safe", Ex i, ignition protection.

These instruments comply with the requirements of 94/9/EC (ATEX) directive for gas and dust. Manufacturer's declarations in accordance with NAMUR NE24 are also available.

The classification/suitability of the instrument (permissible power,  $P_{max}$ , as well as the permissible ambient temperature) for the respective category can be seen on the EC type-examination certificate and in the operating instructions.

Built-in transmitters have their own EC type-examination certificate. The permissible ambient temperature ranges of the built-in transmitters can be taken from the corresponding transmitter approval.

## Functional safety (option)

In safety-critical applications, the entire measuring chain must be taken into consideration in terms of the safety parameters. The SIL classification allows the required risk reduction as well as the associated remaining rest estimation of the measuring chain or the components used.

Selected TC10-E thermocouples in combination with an appropriate temperature transmitter (e.g. model T32.1S) are suitable as sensors for safety functions up to SIL-2.

Matched thermowells allow easy dismounting of the measuring insert for calibration.

The optimally tuned measuring point, consisting of a thermowell, a temperature sensor in the measuring insert and a certified SIL transmitter, provides maximum reliability and a long service life even under extreme conditions.

## Electrical connection

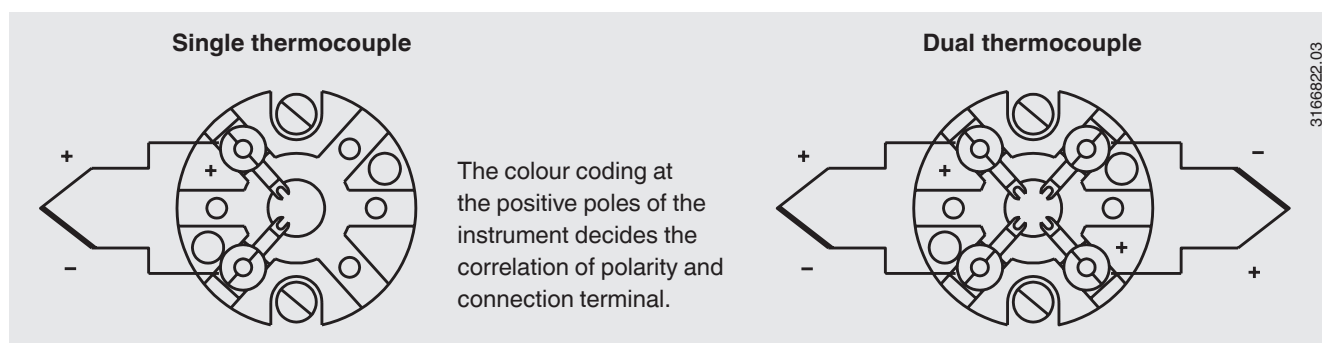

For the electrical connections of built-in temperature transmitters see the corresponding data sheets or operating instructions.

## Ordering information

Model / Explosion protection / Connection head / Cable entry of the connection head / Female thread at connection head / Transmitter / Process connection / Material neck tube / Measuring element / Temperature range / Design of sensor tip / Sensor diameter / Insertion length A (U<sub>2</sub>) / Neck length N(MH) / Certificates / Options

© 2009 WIKA Alexander Wiegand SE & Co. KG, all rights reserved.  
The specifications given in this document represent the state of engineering at the time of publishing.  
We reserve the right to make modifications to the specifications and materials.

