

## Threaded thermocouple Model TC10-D, miniature design

WIKA data sheet TE 65.04



### Applications

- Machine building, plant and vessel construction
- Power train engineering
- Air-conditioning and refrigeration systems

### Special features

- Application ranges from -40 ... +600 °C
- Compact design
- Universal application
- Direct installation into the process
- Explosion-protected versions Ex i, Ex n and NAMUR NE24

### Description

Thermocouples of this series are used for the measurement of liquid or gaseous media at low and medium pressures.

The thermocouple is screwed directly into the process. The electrical connection is made via terminals in the connection head (protected against splashed water). The measuring inserts are available in two variants, depending upon the application. The choice is between a replaceable, spring-loaded miniature measuring insert and a non-replaceable, permanently screwed-in design.

Insertion length, process connection and sensor can each be selected for the respective application.



Threaded thermocouple, miniature design  
model TC10-D

## Sensor

### Sensor type

Model	Recommended max. operating temperature
K (NiCr-Ni)	600 °C
J (Fe-CuNi)	600 °C
E (NiCr-CuNi)	600 °C
T (Cu-CuNi)	350 °C
N (NiCrSi-NiSi)	600 °C

The actual application range of these thermometers is limited both by the permissible maximum temperature of the thermocouple and the sheath material as well as by the permissible maximum temperature of the thermowell material.

Listed thermocouples are available both as single or dual thermocouples. The thermocouple will be delivered with an insulated measuring point, unless explicitly specified otherwise.

### Tolerance value

A cold junction temperature of 0 °C is taken as basis with the definition of the tolerance value of thermocouples.

### Type K

Class	Temperature range	Tolerance value
<b>DIN EN 60584 part 2</b>		
1	-40 ... +375 °C	±1.5 °C
1	+375 ... +1,000 °C	±0.0040 •  t  <sup>1)</sup>
2	-40 ... +333 °C	±2.5 °C
2	+333 ... +1,200 °C	±0.0075 •  t  <sup>1)</sup>
<b>ISA (ANSI) MC96.1-1982</b>		
Standard	0 ... +1,250 °C	±2.2 °C or <sup>2)</sup> ±0.75 %
Special	0 ... +1,250 °C	±1.1 °C or <sup>2)</sup> ±0.4 %

### Type J

Class	Temperature range	Tolerance value
<b>DIN EN 60584 part 2</b>		
1	-40 ... +375 °C	±1.5 °C
1	+375 ... +750 °C	±0.0040 •  t  <sup>1)</sup>
2	-40 ... +333 °C	±2.5 °C
2	+333 ... +750 °C	±0.0075 •  t  <sup>1)</sup>
<b>ISA (ANSI) MC96.1-1982</b>		
Standard	0 ... +750 °C	±2.2 °C or <sup>2)</sup> ±0.75 %
Special	0 ... +750 °C	±1.1 °C or <sup>2)</sup> ±0.4 %

### Type E

Class	Temperature range	Tolerance value
<b>DIN EN 60584 part 2</b>		
1	-40 ... +375 °C	±1.5 °C
1	+375 ... +800 °C	±0.0040 •  t  <sup>1)</sup>
2	-40 ... +333 °C	±2.5 °C
2	+333 ... +900 °C	±0.0075 •  t  <sup>1)</sup>

### Type T

Class	Temperature range	Tolerance value
<b>DIN EN 60584 part 2</b>		
1	-40 ... +125 °C	±0.5 °C
1	+125 ... +350 °C	±0.0040 •  t  <sup>1)</sup>
2	-40 ... +133 °C	±1.0 °C
2	+133 ... +350 °C	±0.0075 •  t  <sup>1)</sup>

### Type N

Class	Temperature range	Tolerance value
<b>DIN EN 60584 part 2</b>		
1	-40 ... +375 °C	±1.5 °C
1	+375 ... +1,000 °C	±0.0040 •  t  <sup>1)</sup>
2	-40 ... +333 °C	±2.5 °C
2	+333 ... +1,200 °C	±0.0075 •  t  <sup>1)</sup>

1) |t| is the value of the temperature in °C irrespective of the sign.

2) Whichever is the greater

Limited error with selected temperatures in °C for thermocouples types K and J

Temperature (ITS 90) °C	Tolerance value DIN EN 60584 part 2	
	Class 1 °C	Class 2 °C
0	±1.5	±2.50
100	±1.5	±2.50
200	±1.5	±2.50
300	±1.5	±2.50
400	±1.6	±3.00
500	±2.0	±3.75
600	±2.4	±4.50

## Measuring insert

### Removable design

Using two screws and springs, the measuring insert can be mounted into a connection head (Form J), replaceable and mounted spring-loaded into the thermowell.

### Fixed design

The measuring insert is manufactured as a unit (as a tube assembly in a thermowell) and thus cannot be replaced. With this design, the temperature is limited to max. 250 °C.

## Components model TC10-D

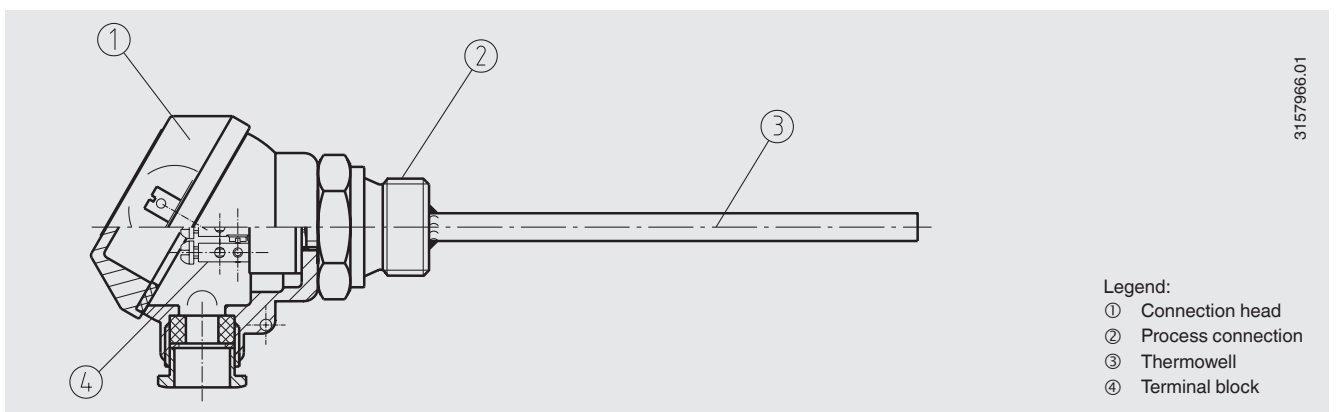

## Connection head

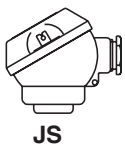

Model	Material	Cable entry	Ingress protection	Cap	Surface finish
JS	Aluminium	M16 x 1.5 <sup>1)</sup>	IP 65	Cap with 2 screws	blue, painted <sup>2)</sup>

1) Standard  
2) RAL 5022

## Transmitter (option)

Within the model JS connection head a model T91.20 analogue temperature transmitter can be factory-fitted. It is mounted in place of the terminal block.

The variant with temperature transmitter is not suitable for use in hazardous areas.

For further technical data on the model T91.20 temperature transmitter please refer to WIKA data sheet TE 91.01.

## Thermowell

■ Material: stainless steel

Thermowell Ø in mm	Insertion length U <sub>1</sub> in mm						
	50	75	100	150	160	250	400
6	x	x	x	x	x	x	x
8	-	-	x	x	x	x	x

## Permissible temperature ranges

- Application ranges -40 ... +600 °C <sup>1)</sup>
- At the head -40 ... +125 °C
- At the transmitter (option) -40 ... +85 °C
- Storage -40 ... +60 °C

1) Sensor type T: Application range -40 ... +350 °C

## Process connections

All process connections are manufactured in stainless steel. Other materials are available on request.

The mounting length A (U<sub>1</sub> or U<sub>2</sub>) can be customised.

The neck length N (M<sub>H</sub>) depends on the type of process connection specified.

## Extended process connection

Connection heads, connecting leads/wires and the optional transmitter must only be used within the above-mentioned temperature ranges.

If the thermometer will operate at temperatures outside of the temperature limits, the clearance between the connection head and the hot or cold surfaces must be increased.

This neck length is dependent upon the intended application and generally serves as isolation or as a cooling element between the process and the connection head.

## Permanent connection

The connection is permanently fixed to the thermowell. The standard neck length is N (M<sub>H</sub>) = 55 mm

## Compression fitting

The compression fitting enables simple, on-site adjustment to the required insertion length.

The self-extending nature of the compression fitting results in the smallest possible neck length, N (M<sub>H</sub>), of around 55 mm.

Since the compression fitting is adjustable on the thermowell, the size of the insertion length, A, and the neck length, N (M<sub>H</sub>), are stated as the values for the delivered item.

- Sealing ring material: stainless steel

Sealing rings from stainless steel are only adjustable once; once the fitting has been loosened it can no longer be tightened onto the thermowell.

## Double threaded hex bushing

Using a double-sided threaded nipple, the thermometer can be screwed directly into the process. In this case the permissible temperature ranges must be observed.

The neck length, N (M<sub>H</sub>), for parallel threads depends on the height of the hexagon. This is 10 mm.

The neck length N of NPT threads not only includes the hexagon height but also half of the thread height. This gives us a neck length, N (M<sub>H</sub>), of approx. 19 mm.

## Without process connection

This version is designed mainly for mounting in one of the available compression fittings.

The neck length N in this case only specifies the height of the hexagon on the head of the thermowell. N (M<sub>H</sub>) is always 7 mm.

## Dimensions in mm

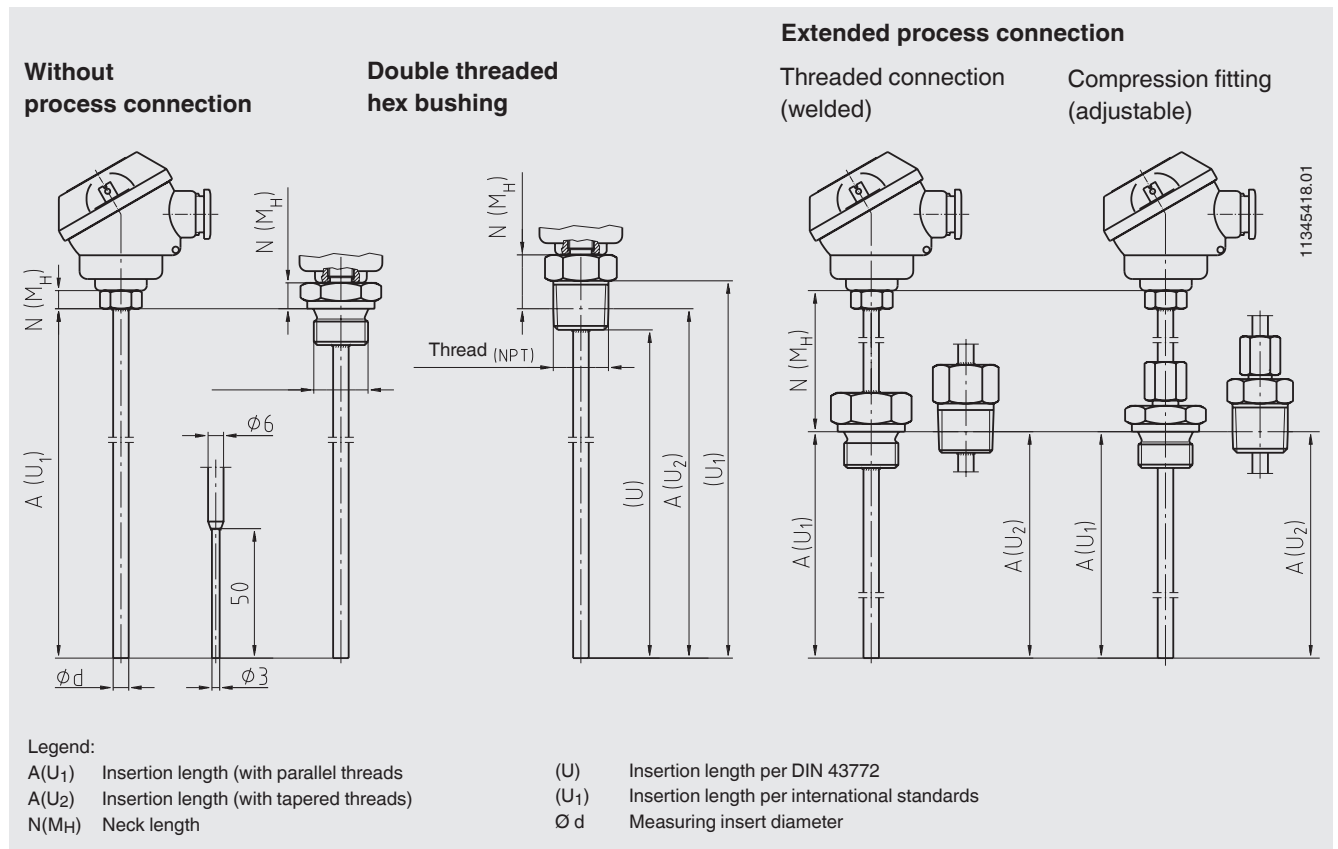

## Explosion protection (option)

Thermocouples of the TC10-D series are available with a EC type-examination certificate for "intrinsically safe", Ex i, ignition protection.

These instruments comply with the requirements of 94/9/EC (ATEX) directive for gas and dust. Manufacturer's declarations in accordance with NAMUR NE24 are also available.

The classification/suitability of the instrument (permissible power  $P_{max}$  as well as the permissible ambient temperature) for the respective category can be seen on the EC type-examination certificate and in the operating instructions.

## Electrical connection

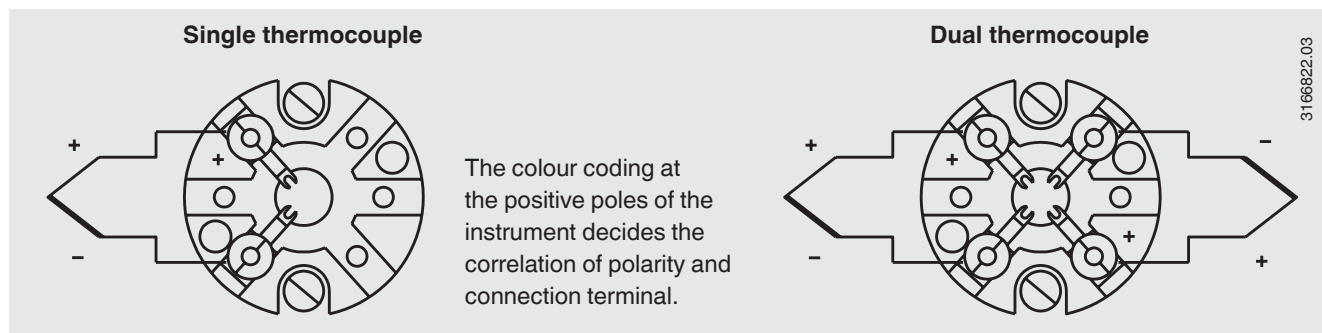

For the electrical connections of built-in temperature transmitters see the corresponding data sheets or operating instructions.

## Ordering information

Model / Design measuring insert / Explosion protection / Process connection / Design and material of the thread / Thread size / Measuring element / Temperature range / Design of sensor tip / Sensor diameter / Insertion length A / Neck length N (M<sub>H</sub>) / Certificates / Options

© 2008 WIKA Alexander Wiegand SE & Co. KG, all rights reserved.  
The specifications given in this document represent the state of engineering at the time of publishing.  
We reserve the right to make modifications to the specifications and materials.



**WIKAL**  
**WIKAL Alexander Wiegand SE & Co. KG**  
Alexander-Wiegand-Straße 30  
63911 Klingenberg/Germany  
Tel. (+49) 9372/132-0  
Fax (+49) 9372/132-406  
E-mail info@wika.de  
www.wika.de