

Resistance thermometer Model TR55, with spring-loaded tip

WIKA data sheet TE 60.55



Applications

Bearing temperature measurement on:

- Pumps
- Gears
- Motors

Special features

- Application ranges from -50 ... +450 °C
- Compact design
- Spring-loaded tip
- Explosion-protected versions Ex-i, Ex-n and NAMUR NE24



Resistance thermometer with spring-loaded tip,
model TR55

Description

The model TR55 resistance thermometer is ideally suited for the measurement of surface temperature at bearings on pumps, gears or motors under dry ambient conditions at the tip. The spring-loaded, flat tip ensures a constant contact pressure of the thermometer on the outer surface of the bearing shell. The optimum insertion depth can be set by means of a compression fitting.

Analogue or digital transmitters built into the connection head are capable of making various output signals available, for example 4 ... 20 mA, HART® protocol, PROFIBUS® PA or FOUNDATION™ fieldbus.

Sensor

Sensor connection method

- 2-wire The lead resistance is recorded as an error in the measurement.
- 3-wire With a cable length of approx. 30 m or longer, measuring errors can occur.
- 4-wire The internal lead resistance of the connecting wires is negligible.

Sensor tolerance value per DIN EN 60751

- Class B
- Class A
- Class AA

The combinations of a 2-wire connection with Class A / Class AA are not permissible, since the lead resistance of the measuring insert negates the higher sensor accuracy.

For detailed specifications for Pt100 sensors, see Technical Information IN 00.17 at www.wika.com.

Process connections

All process connections are manufactured in stainless steel. Other materials are available on request.

The mounting length A (U_1 or U_2) can be customised.

The neck length N depends on the type of the process connection selected.

Compression fitting

The compression fitting enables simple, on-site adjustment to the required insertion length.

Due to the length of the compression fitting itself, the minimum neck length N is 40 mm for parallel threads and 55 mm for NPT threads.

- Compression ring material: stainless steel

Compression rings from stainless-steel are only adjustable once; once the fitting has been loosened it can no longer be tightened onto the thermowell.

Compression rings from PTFE are not recommended.

Without process connection

This version is designed mainly for mounting in one of the available compression fittings.

The neck length N specifies the height of the hexagon below the head.

- Head JS: 7 mm
- Head B: 10 mm

TR55 components

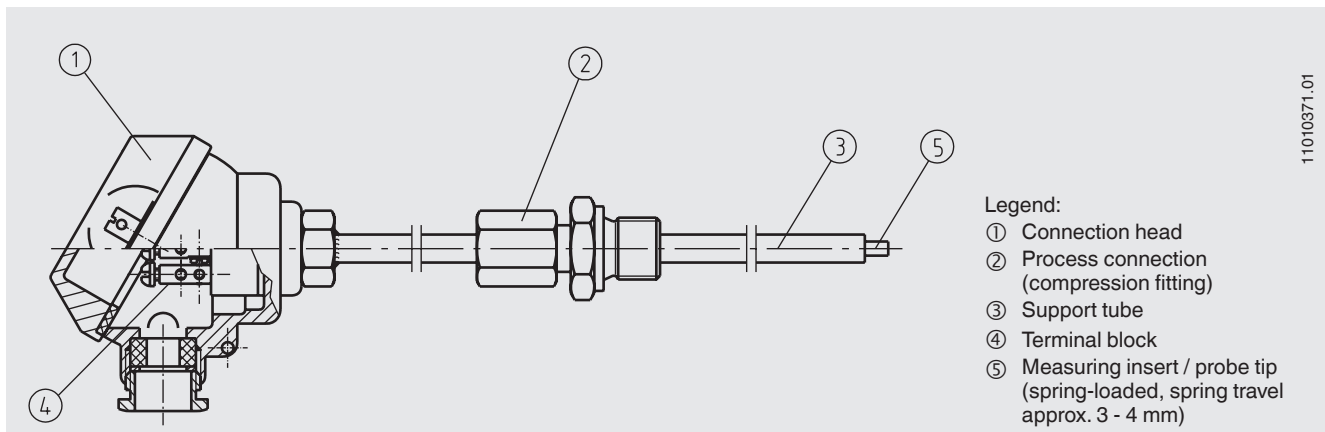

Possible combinations of electrical connection, diameter support tube/probe tip, number of sensors and sensor connection method

Electrical connection	Support tube / probe tip Ø in mm	Sensor 1 x Pt100 Sensor connection method			Sensor 2 x Pt100 Sensor connection method		
		2-wire	3-wire	4-wire	2-wire	3-wire	4-wire
Connection head JS	6 / 3	x	x	x	x	-	-
Connection heads form B	6 / 3	x	x	x	x	x	-
Connection heads form B	8 / 6	x	x	x	x	x	x

Support tube

Serves for the fastening of the compression fitting only and is open at the probe tip (not water-, dust- or gas-tight).

- Material: stainless steel

Support tube Ø in mm	Process connection	Maximum possible insertion length A ¹⁾ in mm with probe length FL							
		65	75	80	85	105	125	230	250
6 or 8	G ¼ B	35	45	50	55	75	95	200	220
	G ⅜ B	35	45	50	55	75	95	200	220
	G ½ B	35	45	50	55	75	95	200	220
	¼ NPT	20	30	35	40	60	80	185	205
	½ NPT	20	30	35	40	60	80	185	205

1) spring not loaded, spring travel approx. 3 to 4 mm (tolerance of insertion lengths ± 2 mm)

Permissible temperature ranges

- Application range: -50 ... +450 °C
- At the head: -40 ... +125 °C (without transmitter)
- At the transmitter: -40 ... +85 °C
- Storage: -40 ... +60 °C

Connection head

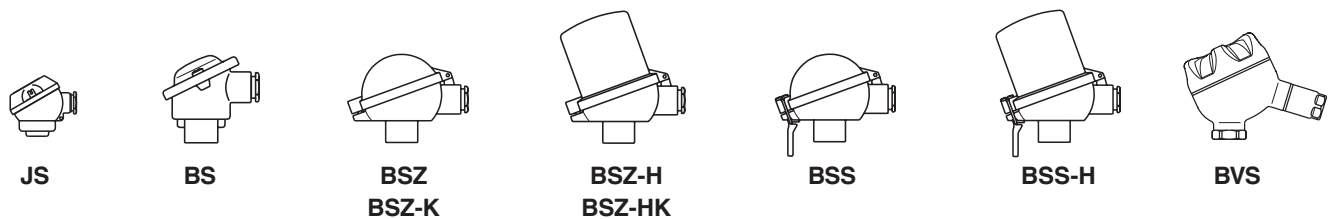

Model	Material	Cable entry	Ingress protection	Cap	Surface finish
JS	Aluminium	M16 x 1.5	IP 54	Cap with 2 screws	blue, painted ²⁾
BS	Aluminium	M20 x 1.5 ¹⁾	IP 65	Cap with 2 screws	blue, painted ²⁾
BSZ	Aluminium	M20 x 1.5 ¹⁾	IP 65	Hinged cover with cylinder head screw	blue, painted ²⁾
BSZ-K	Plastic	M20 x 1.5 ¹⁾	IP 65	Hinged cover with cylinder head screw	black
BSZ-H	Aluminium	M20 x 1.5 ¹⁾	IP 65	Hinged cover with cylinder head screw	blue, painted ²⁾
BSZ-HK	Plastic	M20 x 1.5 ¹⁾	IP 65	Hinged cover with cylinder head screw	black
BSS	Aluminium	M20 x 1.5 ¹⁾	IP 65	Hinged cover with clip	blue, painted ²⁾
BSS-H	Aluminium	M20 x 1.5 ¹⁾	IP 65	Hinged cover with clip	blue, painted ²⁾
BVS	Stainless steel	M20 x 1.5 ¹⁾	IP 65	Screw cover	Precision casting, electropolished

1) Standard

2) RAL5022, polyester paint saltwater-resistant

3) The indicated ingress protection does not apply for the open sensor tip. It is valid for the connection head of a correctly installed thermometer.

Transmitter (option)

Depending on the connection head used, a transmitter can be mounted within the thermometer.

- Mounted instead of terminal block
- Mounted within the cap of the connection head
- Mounting not possible

Connection head	Transmitter model						
	T12	T19	T24	T32	T53	T91.10	T91.20
JS	-	-	-	-	-	-	○
BS	-	○	○	-	○	○	-
BSZ / BSZ-K	○	○	○	○	○	○	-
BSZ-H / BSZ-HK	●	●	●	●	●	●	-
BSS	○	○	○	○	○	○	-
BSS-H	●	●	●	●	●	●	-
BVS	○	○	○	○	○	○	-

Model	Description	Explosion protection	Data sheet
T19	Analogue transmitter, configurable	without	TE 19.03
T24	Analogue transmitter, PC configurable	optional	TE 24.01
T91.10	Analogue transmitter, fixed measuring range	without	TE 91.01
T91.20	Analogue transmitter, fixed measuring range	without	TE 91.01
T12	Digital transmitter, PC configurable	optional	TE 12.03
T32	Digital transmitter, HART® protocol	optional	TE 32.04
T53	Digital transmitter FOUNDATION™ Fieldbus and PROFIBUS® PA	Standard	TE 53.01

Dimensions in mm

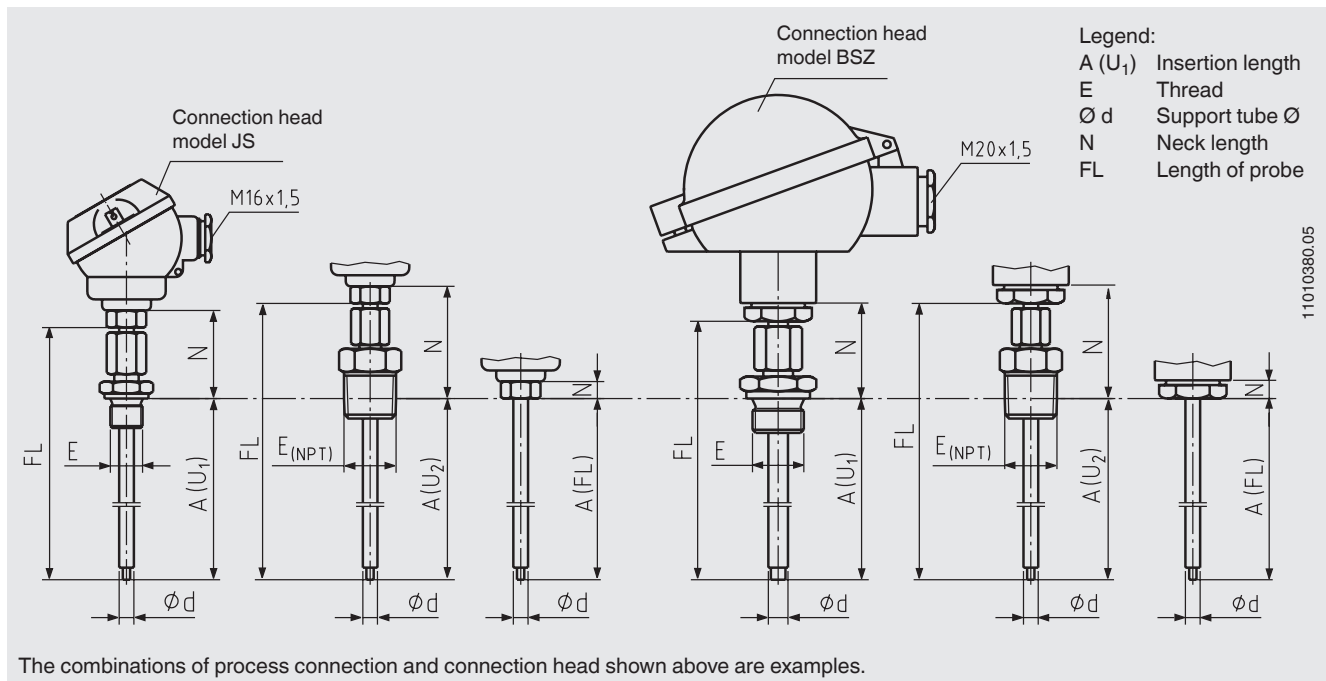

Explosion protection (option)

Resistance thermometers of the TR55 series are available with a EC type-examination certificate for "intrinsically safe", Ex-i, ignition protection.

These instruments comply with the requirements of 94/9/EC (ATEX) directive for gas and dust. Manufacturer's declarations in accordance with NAMUR NE24 are also available.

The classification/suitability of the instrument (permissible power P_{max} as well as the permissible ambient temperature)

for the respective category can be seen on the EC type-examination certificate and in the operating instructions.

Built-in transmitters have their own EC type-examination certificate. The permissible ambient temperature ranges of the built-in transmitters can be taken from the corresponding transmitter approval. The system operator is responsible for using suitable thermowells.

Electrical connection

Connection head JS

1 x Pt100, 2-wire

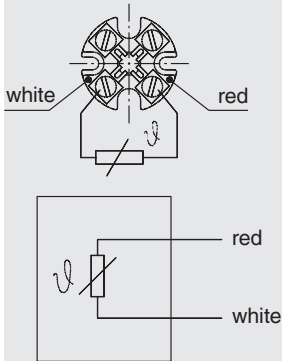

1 x Pt100, 3-wire

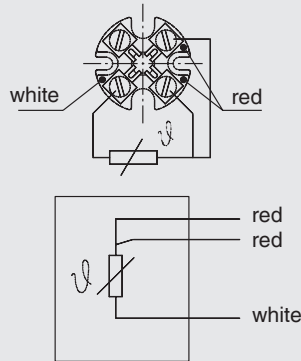

1 x Pt100, 4-wire

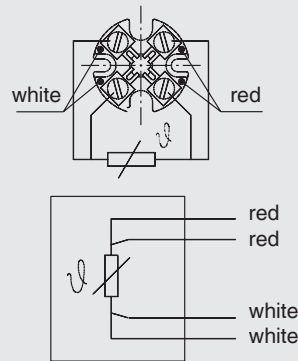

2 x Pt100, 2-wire

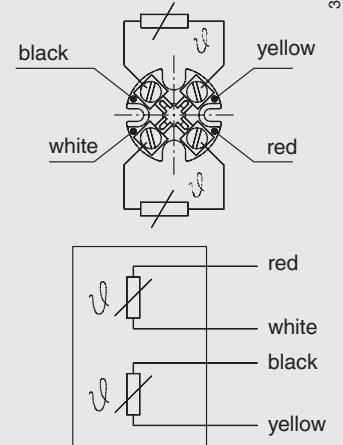

3383942_03

Connection head form B

1 x Pt100, 2-wire

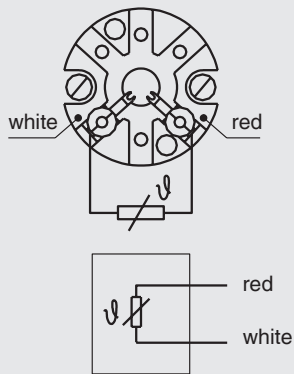

1 x Pt100, 3-wire

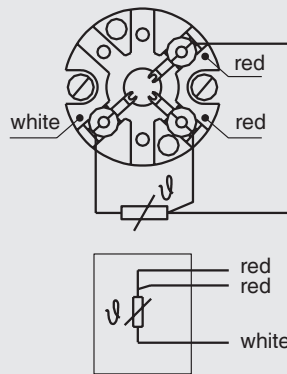

1 x Pt100, 4-wire

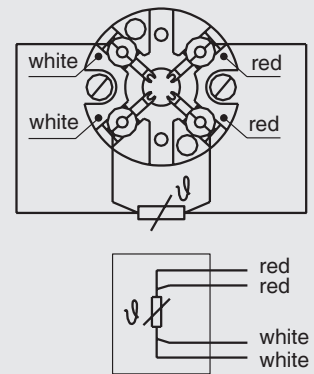

3160629_06

2 x Pt100, 2-wire

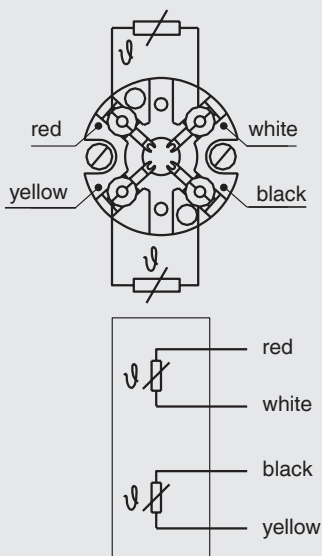

2 x Pt100, 3-wire

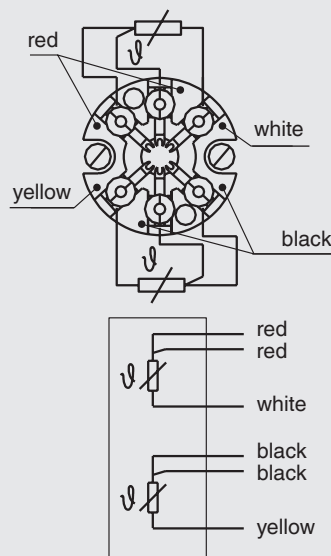

2 x Pt100, 4-wire

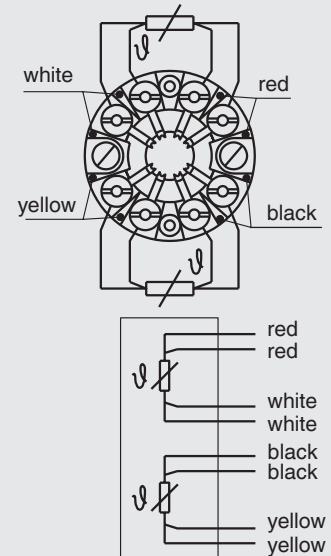

For the electrical connections of built-in temperature transmitters see the corresponding transmitter data sheets or operating instructions.

© 2009 WIKA Alexander Wiegand SE & Co. KG, all rights reserved.
The specifications given in this document represent the state of engineering at the time of publishing.
We reserve the right to make modifications to the specifications and materials.



WIKAL Alexander Wiegand SE & Co. KG
Alexander-Wiegand-Straße 30
63911 Klingenberg/Germany
Tel. (+49) 9372/132-0
Fax (+49) 9372/132-406
E-mail info@wika.de
www.wika.de