

Threaded-Resistance Thermometers Model TR10-J with Perforated Thermowell Model TW35

WIKA Data Sheet TE 60.10

Applications

- Air ducts
- Air conditioning systems
- Ambient temperature measurements with difficult conditions
- Building process control technique
- Sanitary, heating and air-conditioning technology

Special Features

- Application ranges from -200 °C to +600 °C
- With integrated perforated thermowell Model TW35

Description

Resistance thermometers in this series are designed for screw fitting into air ducts.

Due to the perforation of the thermowell the measurement insert is in direct contact with the media. This improves considerably the response time. The measuring insert is sealed to the connection head which means no media can leak out.

Insertion length, process connection, design of thermowell, connection head as well as type and number of sensors, accuracy and method of connection can be selected individually for the respective application.

Optionally we can fit analogue or digital transmitters from the WIKA range into the connection head of the TR10-J.



**Threaded-Resistance Thermometer Model TR10-J
with Perforated Thermowell Model TW35**

Sensor

The sensor is located in the tip of the measuring insert.

Sensor method of connection

- 2-wire The lead resistance of the measuring insert compounds the error.
- 3-wire With a cable length of approx. 30 m or longer measuring deviations can occur.
- 4-wire The inner lead resistance of the connecting wires is negligible.

Sensor limiting error

- Class B to DIN EN 60 751
- Class A to DIN EN 60 751
- 1/3 DIN B at 0 °C

It makes no sense to combine 2-wire connection with class A or 2-wire connection with 1/3 DIN B, because the lead resistance of the measuring insert, over-rides the higher sensor accuracy.

Basic values and limiting errors

Basic values and limiting errors for the platinum measurement resistances are laid down in DIN EN 60 751.

The nominal value of Pt100 sensors is 100 Ω at 0 °C.

The temperature coefficient α can be stated simply to be between 0 °C and 100 °C with:

$$\alpha = 3.85 \cdot 10^{-3} \text{ }^{\circ}\text{C}^{-1}$$

The relationship between the temperature and the electrical resistance is characterised by polynomials which are defined in DIN EN 60 751. Furthermore, this standard lays down the basic values in °C stages.

Class	Limiting error in °C
A	$0.15 + 0.002 \cdot t $ ¹⁾
B	$0.3 + 0.005 \cdot t $

1) |t| is the value of the temperature in °C without consideration of the sign

Temperature (ITS 90) °C	Basic value Ω	Limiting error DIN EN 60 751			
		Class A		Class B	
°C	Ω	°C	Ω	°C	Ω
-200	18.52	± 0.55	± 0.24	± 1.30	± 0.56
-100	60.26	± 0.35	± 0.14	± 0.80	± 0.32
-50	80.31	± 0.25	± 0.10	± 0.55	± 0.22
0	100.00	± 0.15	± 0.06	± 0.30	± 0.12
50	119.40	± 0.25	± 0.10	± 0.55	± 0.21
100	138.51	± 0.35	± 0.13	± 0.80	± 0.30
200	175.86	± 0.55	± 0.20	± 1.30	± 0.48
300	212.05	± 0.75	± 0.27	± 1.80	± 0.64
400	247.09	± 0.95	± 0.33	± 2.30	± 0.79
500	280.98	± 1.15	± 0.38	± 2.80	± 0.93
600	313.71	± 1.35	± 0.43	± 3.30	± 1.06

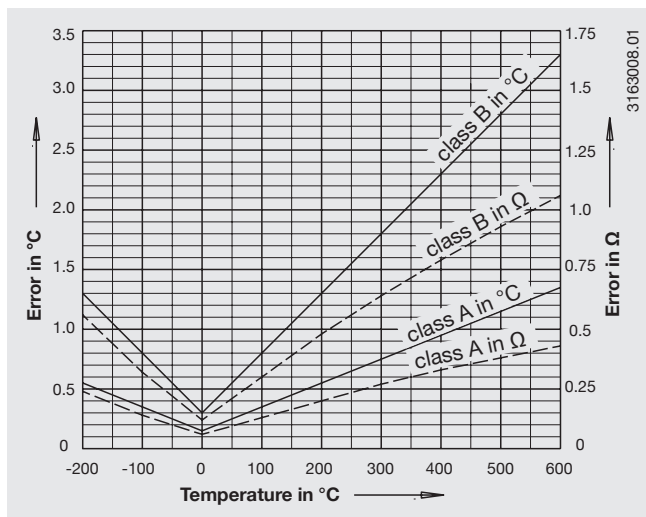

TR10-J components

Fig. with parallel thread, conical thread see page 5

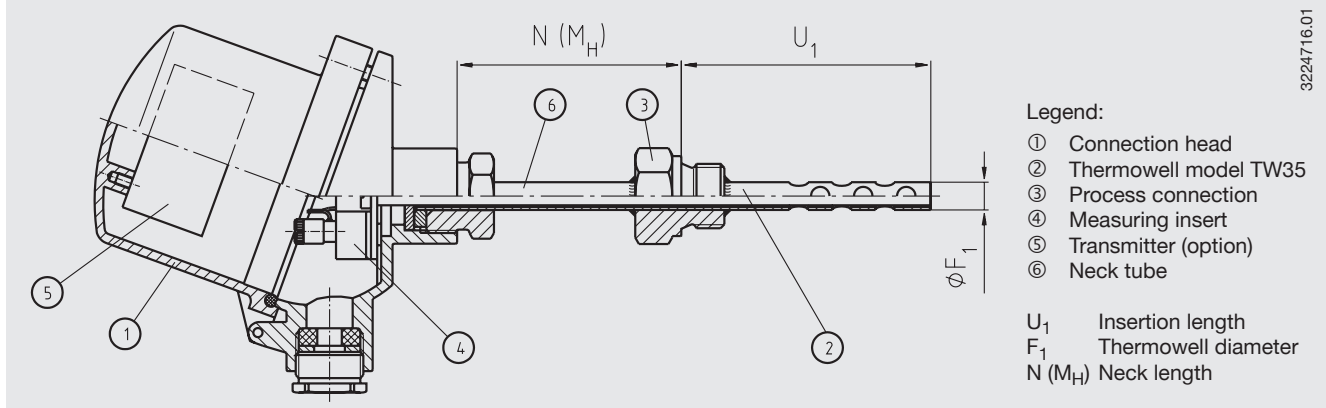

Connection head

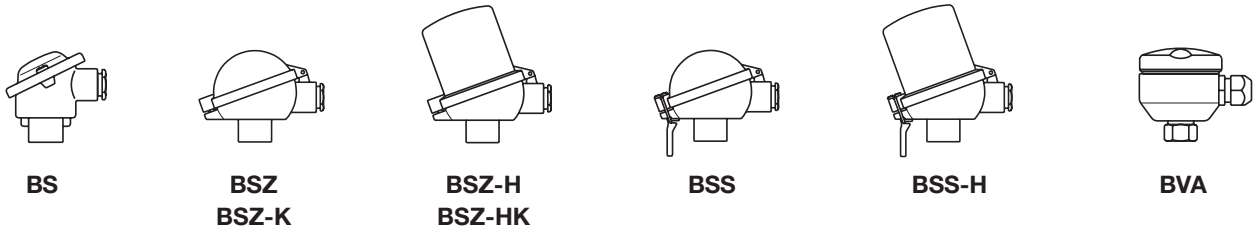

Model	Material	Cabel entry	Ingress protection	Cap	Surface finish
BS	aluminium	M20 x 1.5 ¹⁾	IP 65	Cap with 2 screws	blue, painted ²⁾
BSZ	aluminium	M20 x 1.5 ¹⁾	IP 65	Flap cap with screws	blue, painted ²⁾
BSZ-K	plastic	M20 x 1.5 ¹⁾	IP 65	Flap cap with screws	black
BSZ-H	aluminium	M20 x 1.5 ¹⁾	IP 65	Flap cap with screws	blue, painted ²⁾
BSZ-HK	plastic	M20 x 1.5 ¹⁾	IP 65	Flap cap with screws	black
BSS	aluminium	M20 x 1.5 ¹⁾	IP 65	Flap cap with clip	blue, painted ²⁾
BSS-H	aluminium	M20 x 1.5 ¹⁾	IP 65	Flap cap with clip	blue, painted ²⁾
BVA	stainless steel	M20 x 1.5 ¹⁾	IP 65	Screw cover	blank

1) Standard

2) RAL5022, polyester paint saltwater.proof

Connection head with digital indicator (option)

As an optional alternative to the standard connection head the thermometer may be equipped with the digital indicator DIH10. The connection head used in this case is similar to the head model BSZ-H. For operation a 4 ... 20 mA transmitter is necessary, which is mounted to the measuring insert. The scale range of the indicator is configurated identical to the measuring range of the transmitter. Intrinsically safe versions, explosion protection type EEx (i), are also available.



Fig. Connection head with digital indicator, Model DIH10

Transmitter (option)

Depending on used connection head a transmitter can be mounted into the thermometer.

- Mounted instead of terminal block
- Mounted within the cap of the connection head
- Mounting not possible

Mounting of two transmitters on request.

Connection head	Transmitter Model				
	T12	T19	T24	T32	T53
BS	-	○	○	-	○
BSZ / BSZ-K	○	○	○	○	○
BSZ-H / BSZ-HK	●	●	●	●	●
BSS	○	○	○	○	○
BSS-H	●	●	●	●	●
BVA	○	○	○	○	○

Model	Description	Explosion protection	Data sheet
T19	Analogue transmitter, configurable	without	TE 19.03
T24	Analogue transmitter, PC-configurable	optional	TE 24.01
T12	Digital transmitter, PC-configurable	optional	TE 12.03
T32	Digital transmitter, HART protocol	optional	TE 32.03
T53	Digital transmitter FOUNDATION Fieldbus und PROFIBUS PA	standard	TE 53.01

Thermowell Model TW35

The thermowell is made of drawn tube with welded bottom and screwed into the connection head. The cable entry of the connection head can be aligned.

The process connection is welded onto the thermowell in the factory to customer's own specifications. This also determines the insertion length. Preference is to be given to insertion lengths to DIN Standards, respectively.

Designs to DIN Standards as well as special designs (for example, with tapered thermowell, reinforced extension neck, etc.) are available in stainless steel 1.4571 or special materials on request.

For further technical specifications about the thermowell please see WIKA data sheet TW 95.35.

Design of thermowell model TW35

Design 2G per DIN 43 772

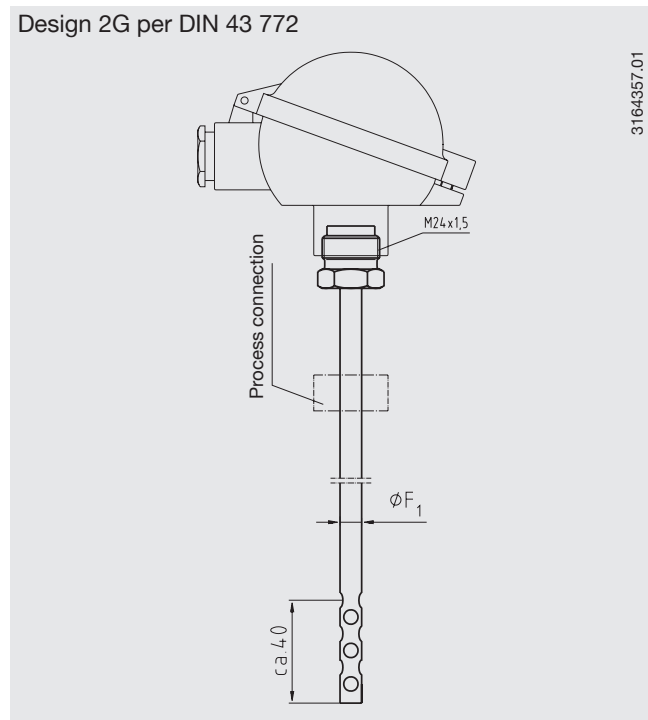

Dimensions in mm

Versions according to DIN 43 772

Design	Insertion length	Process connection	Thermowell outer ϕF_1	Neck length N
Form 2G	160	G 1/2 B, G 1 B	8, 11, 12, 14	130
Form 2G	250	G 1/2 B, G 1 B	8, 11, 12, 14	130
Form 2G	400	G 1/2 B, G 1 B	8, 11, 12, 14	130

Above types are also available with process connection 1/2 NPT. These do not correspond, however, to the DIN 43 772.

Process connection

Design:

- Male thread, welded with thermowell
- Compression fitting, with thermowell diameter 12 mm preferably
(Compression fittings allow simple adaptation to the required insertion length at the installation point. After tightening, the compression fitting can no longer be moved on the thermowell.)
- Union nut

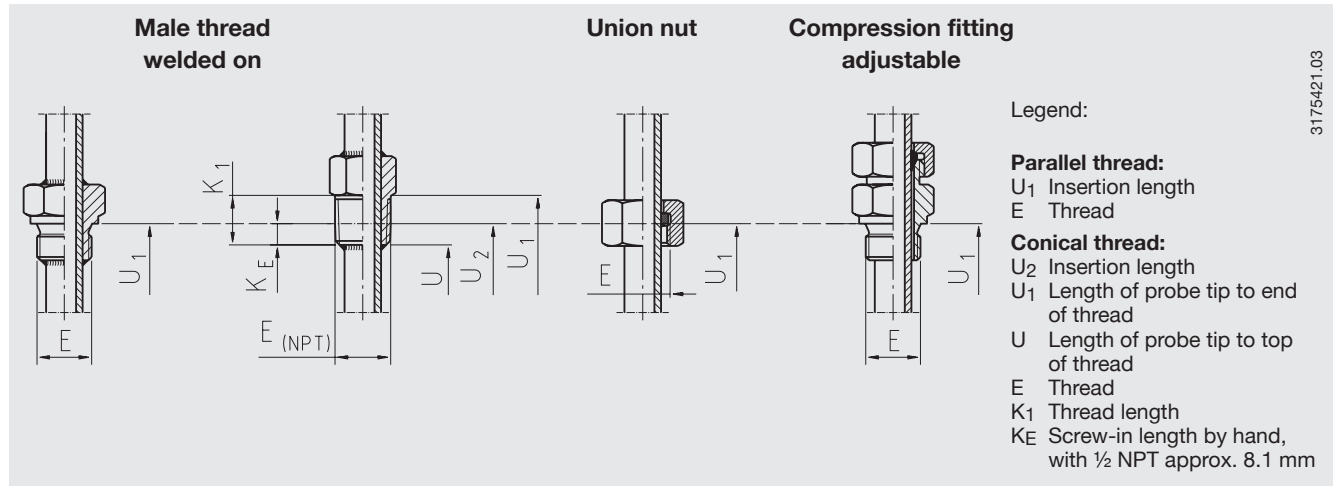

Design of process connection	Thermowell Ø			
	9 mm	11 mm	12 mm	14 mm
Male thread	G ½ B	G ½ B	G ½ B	G ½ B
	-	G 1 B	G 1 B	G 1 B
	½ NPT	½ NPT	½ NPT	½ NPT
	M20 x 1.5	M20 x 1.5	M20 x 1.5	M20 x 1.5
Compression fitting	-	-	G ½ B	-
	-	-	½ NPT	-
Union nut	G ½ B	G ½ B	G ½ B	G ½ B

Electrical connection

3160629_06

1 x Pt100, 2-wire

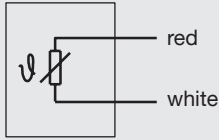
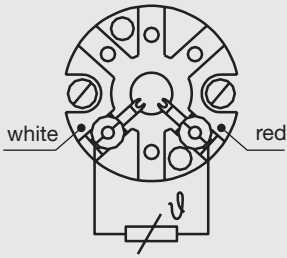

1 x Pt100, 3-wire

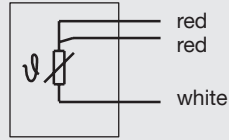
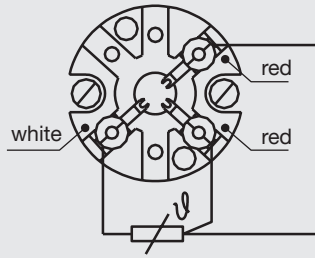

1 x Pt100, 4-wire

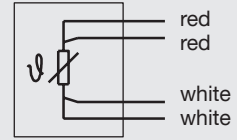
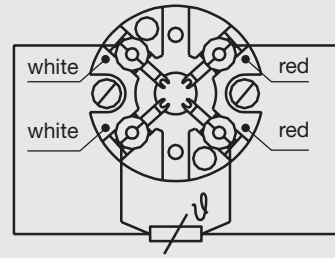

2 x Pt100, 2-wire

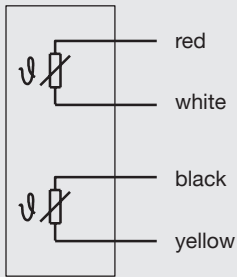
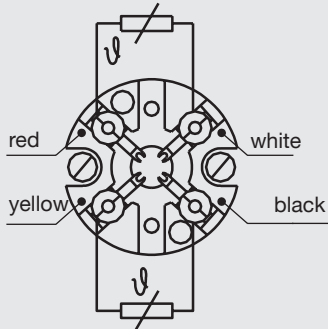

2 x Pt100, 3-wire

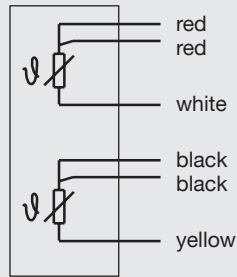
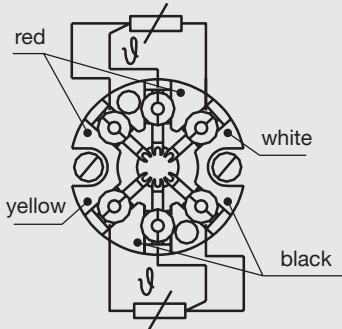

2 x Pt100, 4-wire

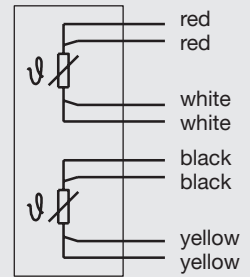
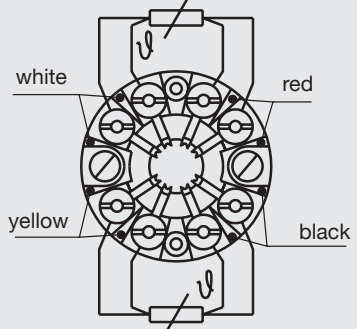

Modifications may take place and materials specified may be replaced by others without prior notice. Specifications and dimensions given in this leaflet represent the state of engineering at the time of printing.



WIKA Alexander Wiegand GmbH & Co. KG
 Alexander-Wiegand-Straße 30
 63911 Klingenberg/Germany
 Tel. (+49) 9372/132-0
 Fax (+49) 9372/132-406
 E-mail info@wika.de
 www.wika.de