

## Threaded resistance thermometer Model TR10-D, miniature design

WIKA data sheet TE 60.04



### Applications

- Machine building, plant and vessel construction
- Power train engineering
- Air-conditioning and refrigeration systems

### Special features

- Application ranges from -200 ... +600 °C
- Compact design
- Universal application
- Direct installation into the process
- Explosion-protected versions Ex-i, Ex-n and NAMUR NE24

### Description

Resistance thermometers of this series are used for the measurement of liquid or gaseous media at low and medium pressures.

The resistance thermometer is screwed directly into the process. The electrical connection is made via terminals in the connection head (protected against splashed water). The measuring inserts are available in two variants, depending upon the application. The choice is between a replaceable, spring-loaded miniature measuring insert and a non-replaceable, permanently screwed-in design.

Insertion length, process connection and sensor can each be selected for the respective application from the order information.



Threaded resistance thermometer, miniature design  
model TR10-D

## Sensor

The sensor is located in the tip of the measuring insert.

### Sensor connection method

- 2-wire The lead resistance is recorded as an error in the measurement.
- 3-wire With a cable length of approx. 30 m or longer, measuring errors can occur.
- 4-wire The internal lead resistance of the connecting wires is negligible.

### Tolerance value of the sensor to DIN EN 60751

- Class B
- Class A
- Class AA

The combination of a 2-wire connection with Class A / Class AA is not permissible, since the lead resistance of the measuring insert negates the higher sensor accuracy.

For detailed specifications for Pt100 sensors, see Technical Information IN 00.17 at [www.wika.com](http://www.wika.com).

## Measuring insert

### Removable design

Using two screws and springs, the measuring insert can be mounted into a connection head (Form J), replaceable and mounted spring-loaded into the thermowell.

### Fixed design

The measuring insert is manufactured as a unit (as a tube assembly in a thermowell) and thus cannot be replaced. With this design, the temperature is limited to a max. of 250 °C.

## TR10-D components

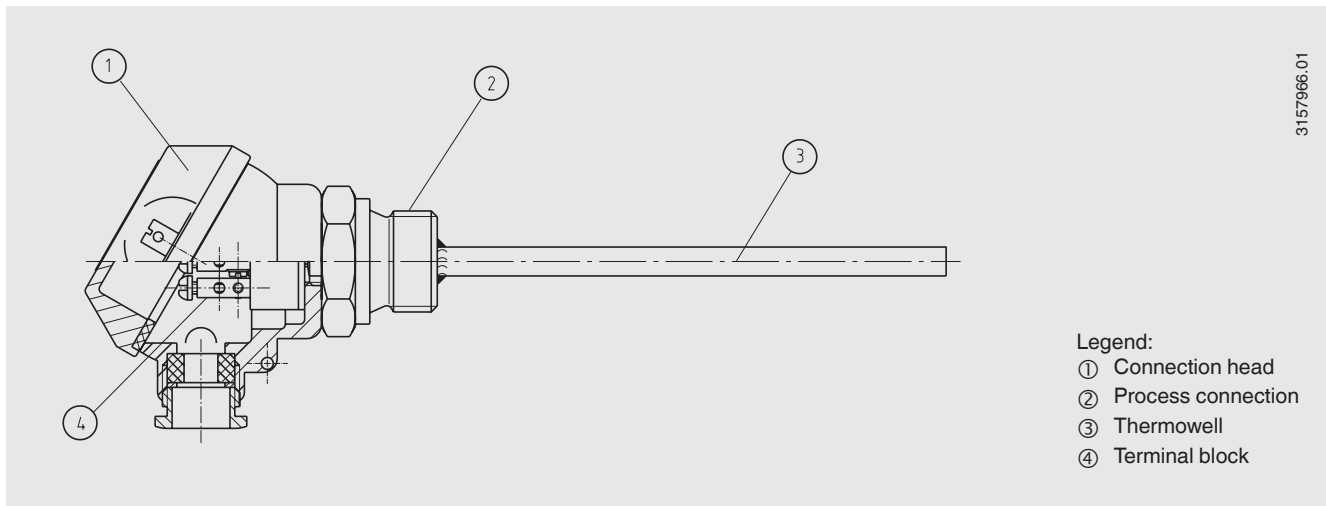

3157966.01

## Connection head

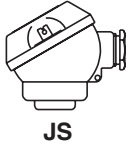

Model	Material	Cable entry	Ingress protection	Cap	Surface finish
JS	Aluminium	M16 x 1.5 <sup>1)</sup>	IP 65	Cap with 2 screws	blue, painted <sup>2)</sup>

1) Standard

2) RAL5022, polyester paint saltwater-resistant

### Transmitter (option)

Within the model JS connection head a model T91.20 analogue temperature transmitter can be factory-fitted. It is mounted in place of the terminal block.

The variant with temperature transmitter is not suitable for use in hazardous areas.

For further technical data on the model T91.20 temperature transmitter, please refer to WIKA data sheet TE 91.01.

### Process connections

All process connections are manufactured in stainless steel. Other materials are available on request.

The insertion length A ( $U_1$  and/or  $U_2$ ) can be specified to customer-specific requirements.

The neck length N ( $M_H$ ) depends on the type of process connection specified.

### Thermowell

- Material: stainless steel

Thermowell Ø in mm	Insertion length $U_1$ in mm						
	50	75	100	150	160	250	400
6	x	x	x	x	x	x	x
8	-	-	x	x	x	x	x

### Extended process connection

Connection heads, connecting leads/wires and the optional transmitter must only be used within the above-mentioned temperature ranges.

If the thermometer will operate at temperatures outside of the temperature limits, the clearance between the connection head and the hot or cold surfaces must be increased.

This neck length is dependent upon the intended application and generally serves as isolation or as a cooling element between the process and the connection head.

### Permissible temperature ranges

- Application ranges (sensor): -50 ... +450 °C
- At the head: -40 ... +125 °C
- At the transmitter (optional): -40 ... +85 °C
- Storage: -40 ... +60 °C

### Permanent connection

The connection is permanently fixed to the thermowell. The standard neck length is  $N (M_H) = 55$  mm

## Compression fitting

The compression fitting enables simple, on-site adjustment to the required insertion length.

The self-extending nature of the compression fitting results in the smallest possible neck length,  $N (M_H)$ , of around 55 mm.

Since the compression fitting is adjustable on the thermowell, the size of the insertion length,  $A$ , and the neck length,  $N (M_H)$ , are stated as the values for the delivered item

- Sealing ring material: stainless-steel or PTFE

Sealing rings from stainless-steel are only adjustable once; once the fitting has been loosened it can no longer be tightened onto the thermowell.

Sealing rings from PTFE can be adjusted numerous times; once the fitting has been loosened it can again be tightened onto the thermowell.

- Max. temperature at the process connection 150 °C

## Double nipple

Via a two-sided threaded nipple, the thermometer can be screwed directly into the process. For this, the permitted temperature ranges must be followed.

As a result of the parallel threads the neck length,  $N (M_H)$ , is the height of the hex nut. This is 10 mm.

For NPT threads, the length,  $N (M_H)$ , includes half of the thread length, as well as the hex nut height. Thus the neck length,  $N (M_H)$ , is around 19 mm.

## Without process connection

This design is intended primarily for assembly in an already-existing compression fitting.

The neck length,  $N$ , here is only the height of the hex nut at the top of the thermowell.  
 $N (M_H)$  is always 7mm.

## Dimensions in mm

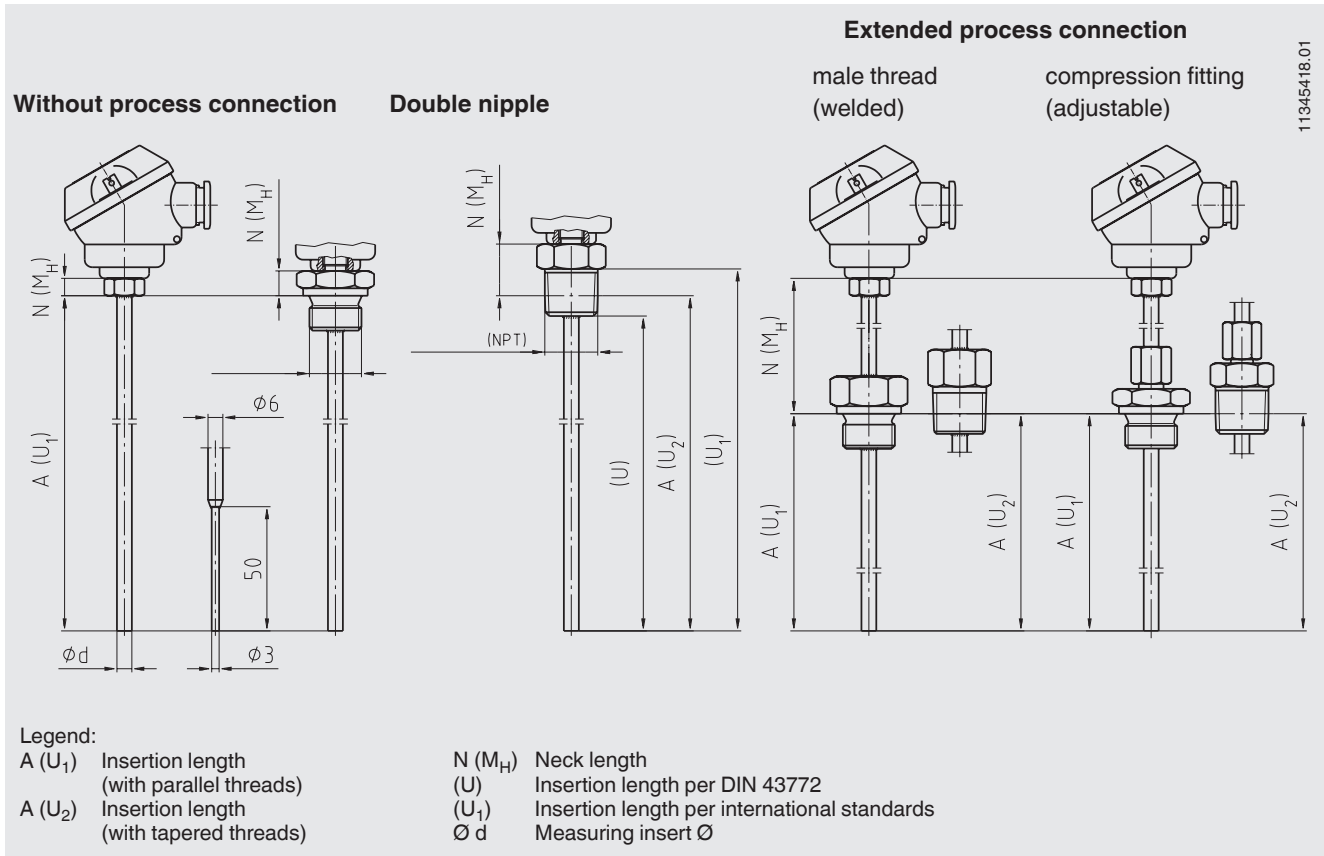

## Explosion protection (option)

Resistance thermometers of the TR10-D series are available with a type-examination certificate for "intrinsically safe", Ex-i, ignition protection.

These instruments comply with the requirements of 94/9/EC (ATEX) directive for gas and dust. Manufacturer's declarations in accordance with NAMUR NE24 are also available.

The classification/suitability of the instrument (permissible power,  $P_{max.}$ , the minimum neck length and permissible ambient temperature) for the respective category can be seen on the type-examination certificate and in the operating instructions.

Instrument designs with non-adjustable measuring inserts are not suitable for use in Zone 0.

The minimum neck length is defined as the distance between the lower edge of the connection head and the heat-radiating surface and is to be selected in accordance with the type examination certificate / operating instructions.

## Electrical connection

### Connection head JS

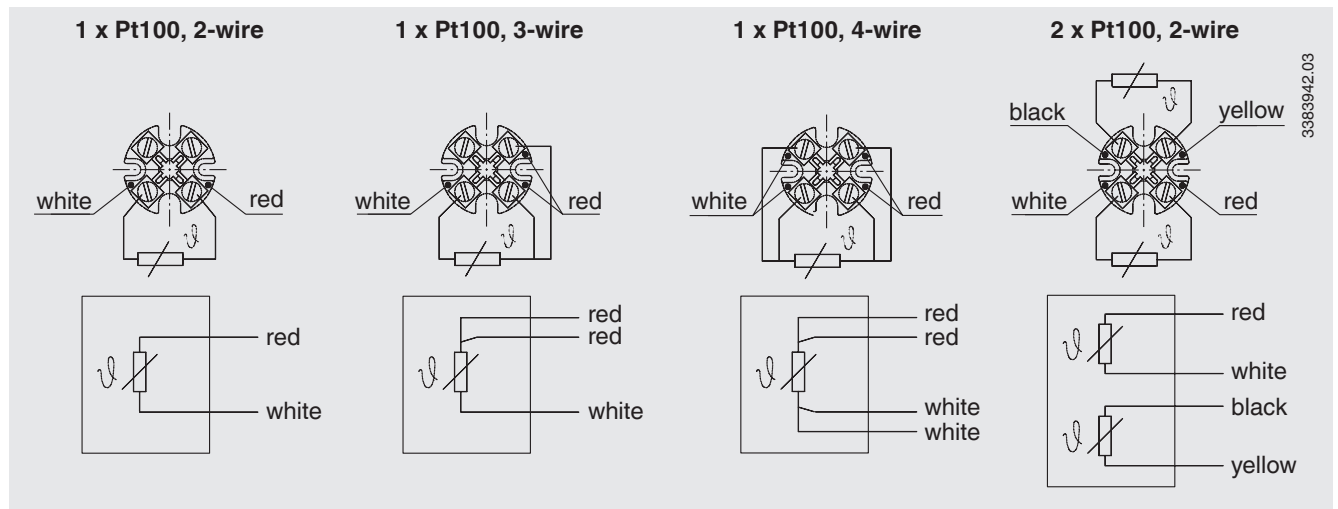

© 2008 WIKA Alexander Wiegand SE & Co. KG, all rights reserved.  
The specifications given in this document represent the state of engineering at the time of publishing.  
We reserve the right to make modifications to the specifications and materials.

