

Resistance thermometer Model TR10-B, for additional thermowell

WIKA data sheet TE 60.02



Applications

- Machine building, plant and tank construction
- Energy and power plant technology
- Chemical industry
- Food and beverage industry
- Sanitary, heating and air-conditioning technology

Special features

- Application ranges from -200 ... +600 °C
- For mounting in all standard thermowell designs
- Spring-loaded measuring insert (replaceable)
- Explosion-protected versions Ex-i, Ex-n and NAMUR NE24

Description

Resistance thermometers of this series can be combined with a large number of thermowell designs. Operation without thermowell is only recommended for specific applications.

An extensive range of sensors, connection heads, insertion lengths, neck lengths, thermowell connections etc. are available for these thermometers, so that they are suitable for all thermowell dimensions and applications.

Optionally we can fit analogue or digital transmitters from the WIKA range into the connection head of the TR10-B.



Resistance thermometer for additional thermowell,
model TR10-B

Sensor

The sensor is located in the measuring insert. This is exchangeable and spring-loaded.

Sensor method of connection

- 2-wire The lead resistance is recorded as an error in the measurement.
- 3-wire With a cable length of approx. 30 m or longer measuring deviations can occur.
- 4-wire The inner lead resistance of the connecting wires is negligible.

Tolerance value of the sensor to DIN EN 60751

- Class B
- Class A
- Class AA

The combinations of a 2-wire connection with Class A / Class AA are not permissible, because the lead resistance of the measuring insert overrides the higher sensor accuracy.

For detailed specifications for Pt100 sensors, see Technical Information IN 00.17 at www.wika.com.

Measuring insert

The measuring insert is made of a vibration-resistant sheathed mineral-insulated cable (MI cable).

The diameter of the measuring insert shall be approx. 1 mm smaller than the bore diameter of the thermowell.

Gaps of more than 0.5 mm between thermowell and measuring insert will have a negative effect on the heat transfer, and they will result in an unfavourable response behaviour of the thermometer.

When fitting the measuring insert with a thermowell, it is very important to determine the correct insertion length (= thermowell length with bottom thicknesses of ≤ 5.5 mm). In this connection the fact that the measuring insert is spring-loaded (spring travel: max. 10 mm) has to be taken into account in order to ensure that the measuring insert presses against the bottom of the thermowell.

Furthermore we recommend that a neck length be selected to give a standard length for the thermometer's measuring insert. This has the advantage that a measuring insert of the standard series can be used.

Neck tube

The neck tube is screwed to the connection head.

The usual size to industrial standards is M24 x 1.5. The length of the neck tube depends on the application. Generally the neck tube serves for the bridging of an insulation. In many applications it is also used as a part cooling element between connection head and medium in order to protect any head mount transmitters from high medium temperatures. The standard material of the neck tube is stainless steel.

Standard measuring insert lengths

Measuring insert Ø in mm	Standard measuring insert lengths in mm											
	275	315	345	375	405	435	525	555	585	655	735	
3	275	315		375		435						
6	275	315	345	375	405	435	525	555	585	655	735	
8	275	315	345	375	405	435	525	555	585	655	735	

The lengths specified in this table correspond to the standard lengths. Intermediate lengths or excess lengths are possible without any problems.

Possible combinations of measuring insert diameter, number of sensors and sensor method of connection

Measuring insert Ø in mm	Sensor / method of connection 1 x Pt100			Sensor / method of connection 2 x Pt100		
	2-wire	3-wire	4-wire	2-wire	3-wire	4-wire
3	x	x	x	x	x	-
6	x	x	x	x	x	x
8	x	x	x	x	x	x

Possible combinations of design, neck tube diameter and connection thread

Design of the screw connection at the neck tube	Connection thread at neck tube		Connection thread to the head
	Ø 12 mm	Ø 14 mm	
Male thread	G ½ B	G ½ B	M24 x 1.5
	G ¾ B	G ¾	M24 x 1.5
	M14 x 1.5	-	M24 x 1.5
	M18 x 1.5	M18 x 1.5	M24 x 1.5
	½ NPT	½ NPT	M24 x 1.5
Union nut	¾ NPT	¾ NPT	M24 x 1.5
	G ½	G ½	M24 x 1.5
Male nut	M27 x 2	M27 x 2	M24 x 1.5
	G ½ B	G ½ B	M24 x 1.5
Neck tube without thread	-	-	M24 x 1.5
Neck tube with compression fitting	G ½ B	G ½ B	M24 x 1.5
	M27 x 2	M27 x 2	M24 x 1.5

TR10-B components

Fig. with parallel thread, conical thread see " Connection to thermowell"

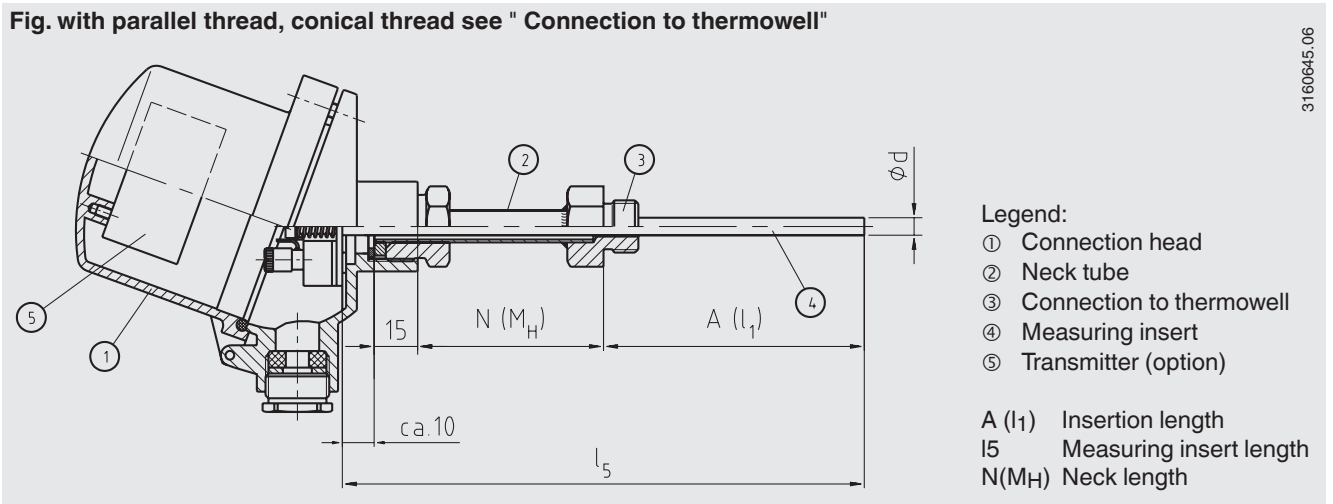

3160645.06

Connection to thermowell

The numerous possible designs ensure that the resistance thermometer, model TR10-B, can be combined with almost all feasible thermowells. The standard designs of connection are shown in the following drawings. Others are available on request.

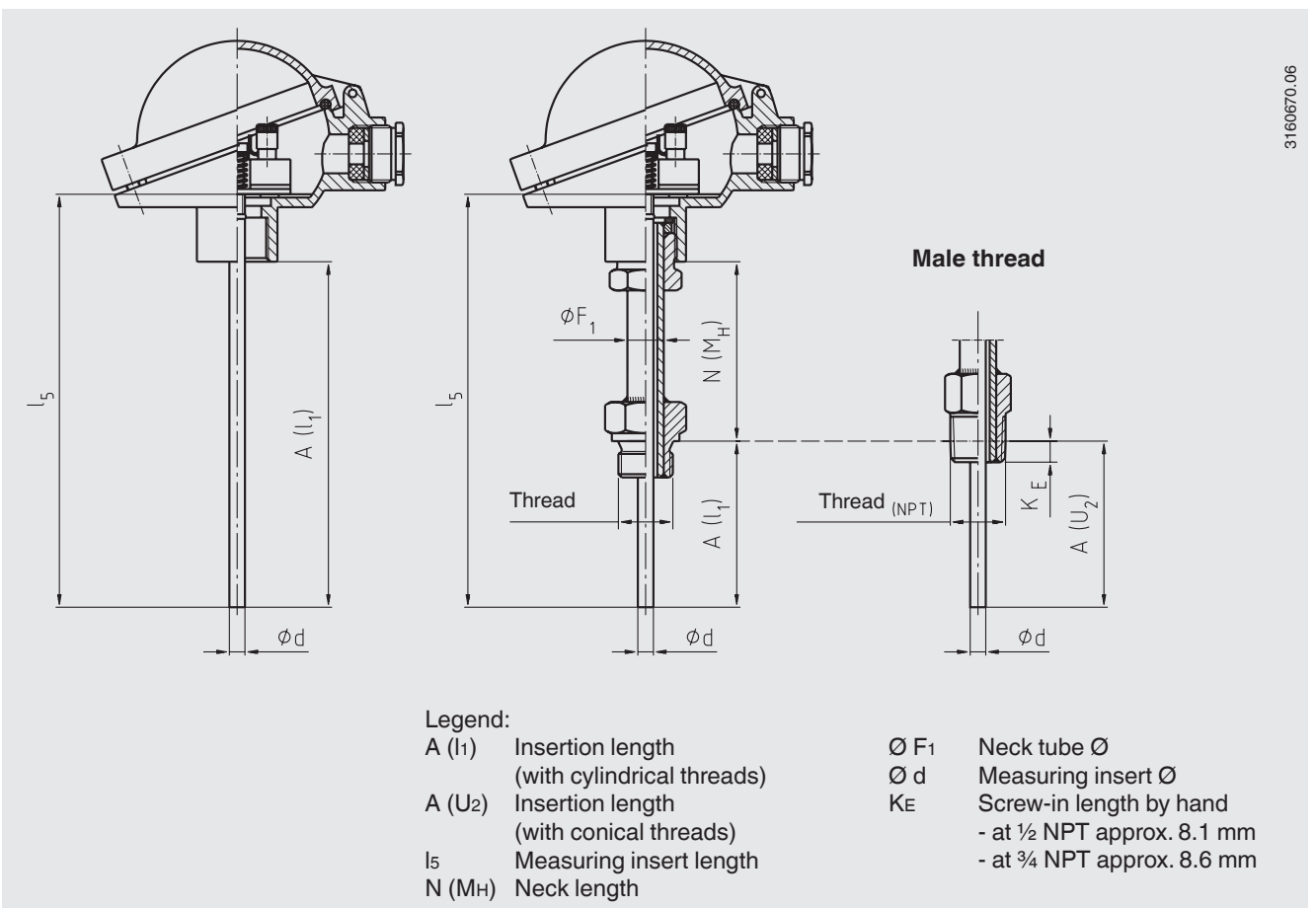

3160670.06

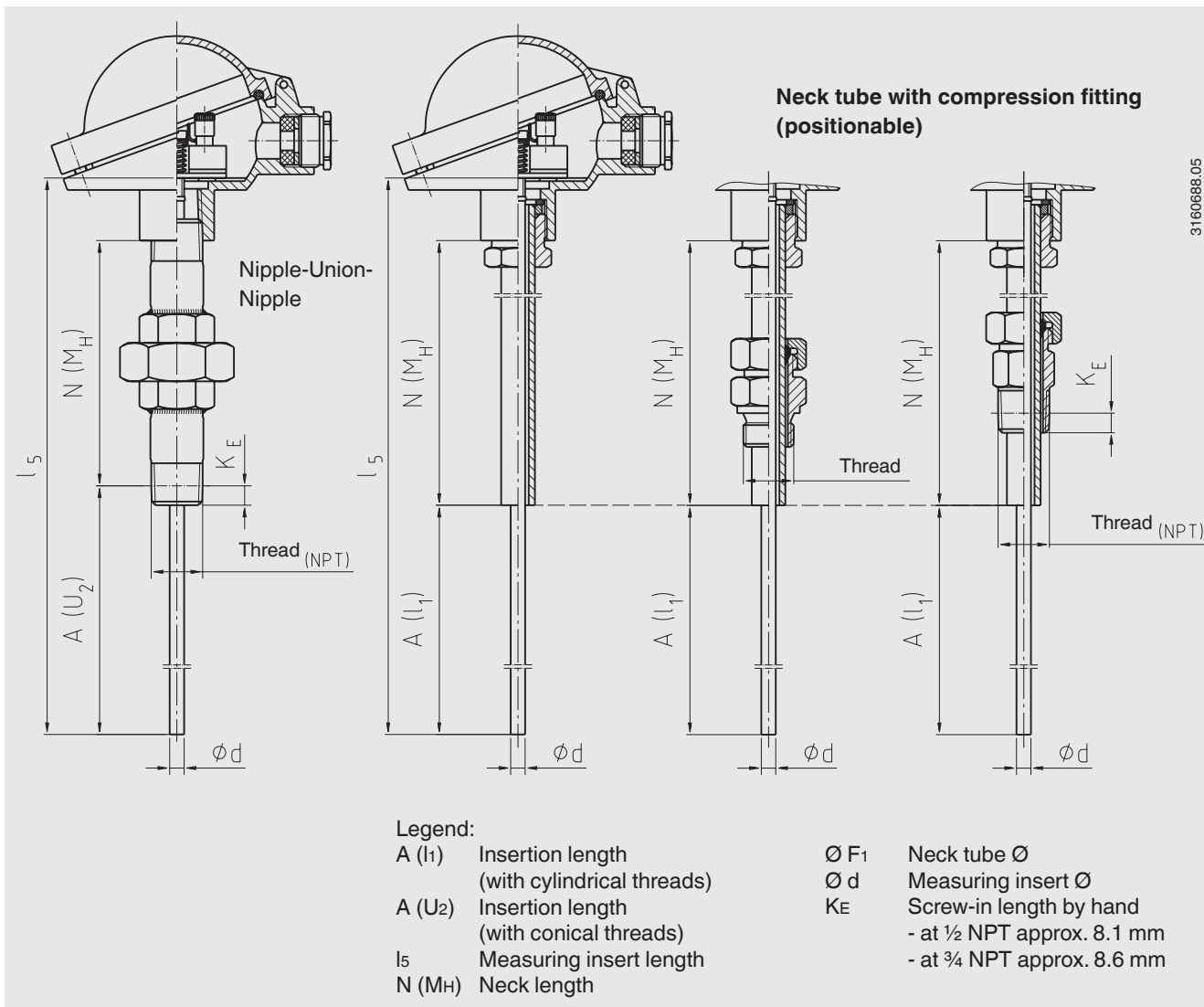

Connection head

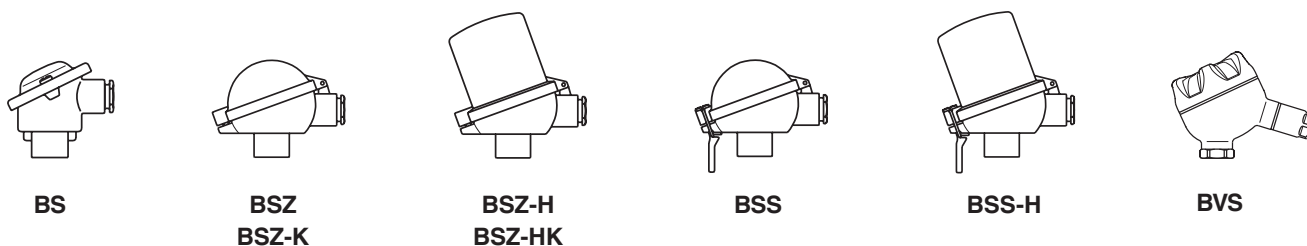

Model	Material	Cable entry	Ingress protection	Cap	Surface finish
BS	Aluminium	M20 x 1.5 ¹⁾	IP 65	Cap with 2 screws	blue, painted ²⁾
BSZ	Aluminium	M20 x 1.5 ¹⁾	IP 65	Flap cap with cylinder head screw	blue, painted ²⁾
BSZ-K	Plastic	M20 x 1.5 ¹⁾	IP 65	Flap cap with cylinder head screw	black
BSZ-H	Aluminium	M20 x 1.5 ¹⁾	IP 65	Flap cap with cylinder head screw	blue, painted ²⁾
BSZ-HK	Plastic	M20 x 1.5 ¹⁾	IP 65	Flap cap with cylinder head screw	black
BSS	Aluminium	M20 x 1.5 ¹⁾	IP 65	Flap cap with clip	blue, painted ²⁾
BSS-H	Aluminium	M20 x 1.5 ¹⁾	IP 65	Flap cap with clip	blue, painted ²⁾
BVS	Stainless steel	M20 x 1.5 ¹⁾	IP 65	Screw cover	Precision casting, electropolished

1) Standard
2) RAL5022, polyester paint saltwater-proof

Connection head with digital indicator (option)

As an optional alternative to the standard connection head the thermometer can be equipped with the digital indicator DIH10. The connection head used in this case is similar to the head model BSZ-H. For operation a 4 ... 20 mA transmitter is necessary, which is mounted to the measuring insert. The scale range of the indicator is configured identically to the measuring range of the transmitter.

Designs in ignition protection type "intrinsically safe" Ex-i are also available.



Fig. connection head with digital indicator, model DIH10

Transmitter (option)

Depending on used connection head a transmitter can be mounted into the thermometer.

- Mounted instead of terminal block
- Mounted within the cap of the connection head
- Mounting not possible

Connection head	Transmitter model				
	T12	T19	T24	T32	T53
BS	-	○	○	-	○
BSZ / BSZ-K	○	○	○	○	○
BSZ-H / BSZ-HK	●	●	●	●	●
BSS	○	○	○	○	○
BSS-H	●	●	●	●	●
BVS	○	○	○	○	○

Mounting of two transmitters on request.

Model	Description	Explosion protection	Data sheet
T19	Analogue transmitter, configurable	without	TE 19.03
T24	Analogue transmitter, PC configurable	optional	TE 24.01
T12	Digital transmitter, PC configurable	optional	TE 12.03
T32	Digital transmitter, HART® protocol	optional	TE 32.04
T53	Digital transmitter FOUNDATION™ Fieldbus and PROFIBUS® PA	standard	TE 53.01

Explosion protection (option)

Resistance thermometers of the model series TR10-B are available with a EC type-examination certificate for "intrinsically safe" Ex-i ignition protection. These thermometers comply with the requirements of directive 94/9/EC (ATEX) for gases and dust. Manufacturer's Declarations in accordance with NAMUR NE24 are also available.

The classification/suitability of the instrument (permissible power P_{max} , as well as the permissible ambient temperature) for the respective category can be seen on the EC type-examination certificate and in the operating instructions.

Built-in transmitters have their own EC type-examination certificate. The permissible ambient temperature ranges of the built-in transmitters can be taken from the corresponding transmitter approval. The system operator is responsible for using suitable thermowells.

Electrical connection

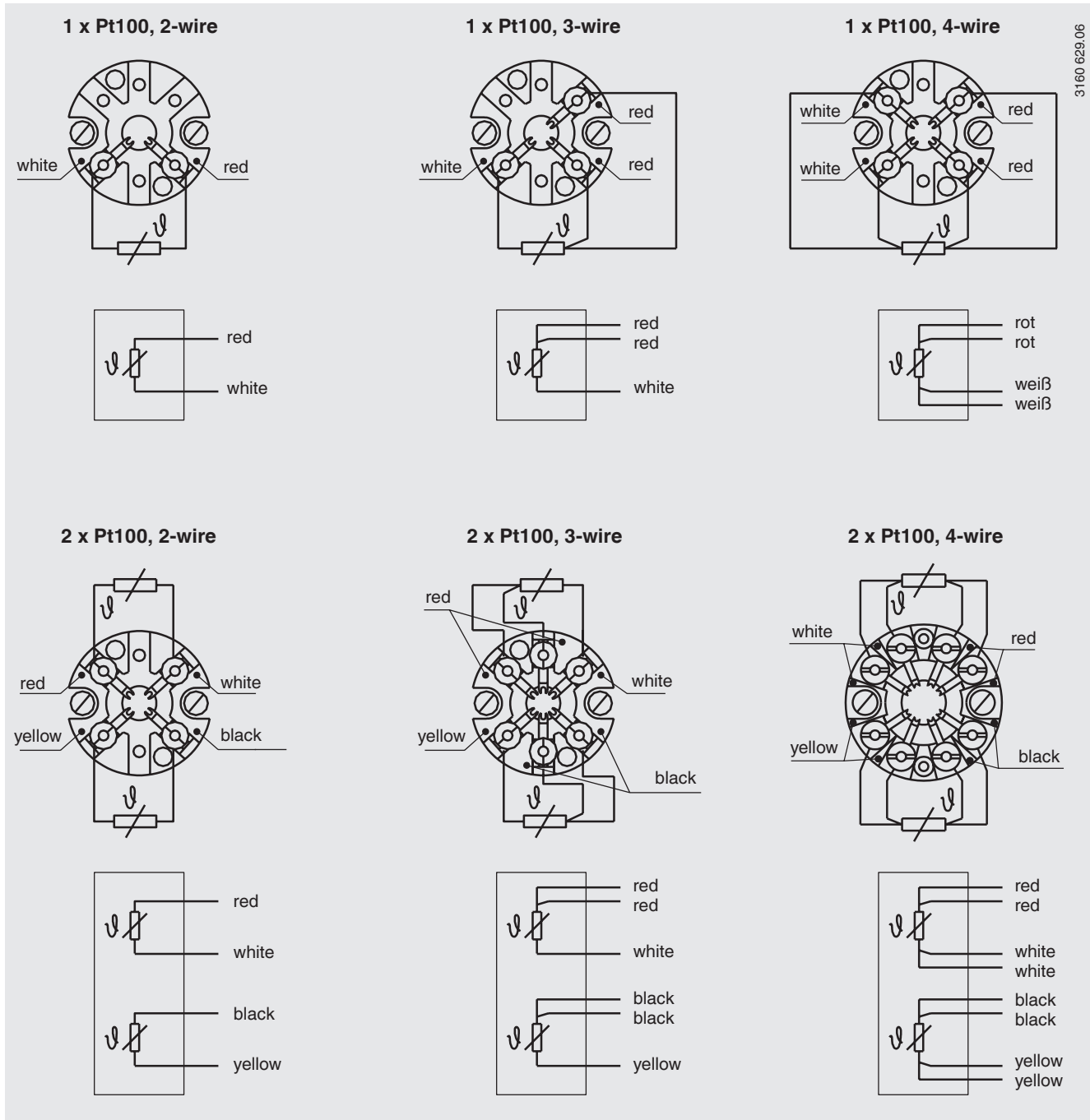

For the electrical connections of built-in temperature transmitters see the corresponding transmitter data sheets or operating instructions.

© 2003 WIKA Alexander Wiegand SE & Co. KG, all rights reserved.
 The specifications given in this document represent the state of engineering at the time of publishing.
 We reserve the right to make modifications to the specifications and materials.



WIKAI Alexander Wiegand SE & Co. KG
 Alexander-Wiegand-Straße 30
 63911 Klingenberg/Germany
 Tel. (+49) 9372/132-0
 Fax (+49) 9372/132-406
 E-mail info@wika.de
 www.wika.de