

Resistance thermometer measuring insert Model TR10-A, standard version Model TR10-K, for flameproof enclosure

WIKA data sheet TE 60.01



Applications

- For all industrial and laboratory applications
- Replacement measuring insert for servicing
model TR10-A: standard version
model TR10-K: for flameproof enclosure (model TR10-L)

Special features

- Application ranges from -200 ... +600 °C
- Made of mineral-insulated sheathed cable
- For all standard thermowell designs
- Spring-loaded design
- Explosion-protected versions

Description

The measuring inserts per DIN 43735 for resistance thermometers described here are designed for installation in a protection assembly. Operation without thermowell is only recommended in certain applications. These measuring inserts are made from flexible, mineral insulated sheathed cable. The sensor is located at the tip of the measuring insert. This model is spring-loaded to ensure that the measuring insert is firmly pressed down on the thermowell bottom. Apart from the DIN versions, customer specific versions are available, for example:

- with mounted sleeve to suit inner diameter of the thermowell
- without terminal block
- with transmitter

Models with rigid insert tube are also available.

Type and number of sensors, accuracy and method of connection can be selected individually for the appropriate



Resistance thermometer measuring inserts

Fig. left: model TR10-A

Fig. right: model TR10-K

application. Adequate heat transfer between thermowell and measuring insert is only ensured when the measuring insert is of correct length and diameter. Selection of standard lengths enables short delivery time and ensures a cost-effective storing as a replacement measuring insert for the corresponding standard dimension.

The range of applications is completed by designs without terminal block for direct transmitter installation. Optionally we can fit analogue or digital transmitters from the WIKA range.

Sensor

The sensor is located at the non-bendable tip of the measuring insert.

Sensor connection method

- 2-wire The lead resistance is recorded as an error in the measurement.
- 3-wire With a cable length of approx. 30 m or longer, measuring errors can occur.
- 4-wire The internal lead resistance of the connecting wires is negligible.

Tolerance value of the sensor to DIN EN 60751

- Class B
- Class A
- Class AA

The combinations of a 2-wire connection with Class A / Class AA are not permissible, since the lead resistance of the measuring insert negates the higher sensor accuracy.

For detailed specifications for Pt100 sensors, see Technical Information IN 00.17 at www.wika.com.

Measuring insert

The measuring insert is made of a vibration-resistant sheathed mineral-insulated cable (MI cable). The diameter of the measuring insert should be approx. 1 mm smaller than the bore diameter of the thermowell. Gaps of more than 0.5 mm between thermowell and the measuring insert will have a negative effect on the heat transfer, and they will result in unfavourable response behaviour from the thermometer.

It is possible to ensure a spring-loaded installation of the measuring insert by means of two screws and springs in a connection head (form B).

When fitting the measuring insert with a thermowell, it is very important to determine the correct insertion length (= thermowell length with bottom thicknesses of ≤ 5.5 mm). In this connection the fact that the measuring insert is spring-loaded (spring travel: max. 10 mm) has to be taken into account in order to ensure that the measuring insert presses against the bottom of the thermowell.

The standard material used for the measuring insert sheath is stainless steel. Other materials are available on request.

Apart from being flexible this model has outstanding resistance to vibration (3 g, for TR10-A optional also 10 g possible).

Dimensions in mm

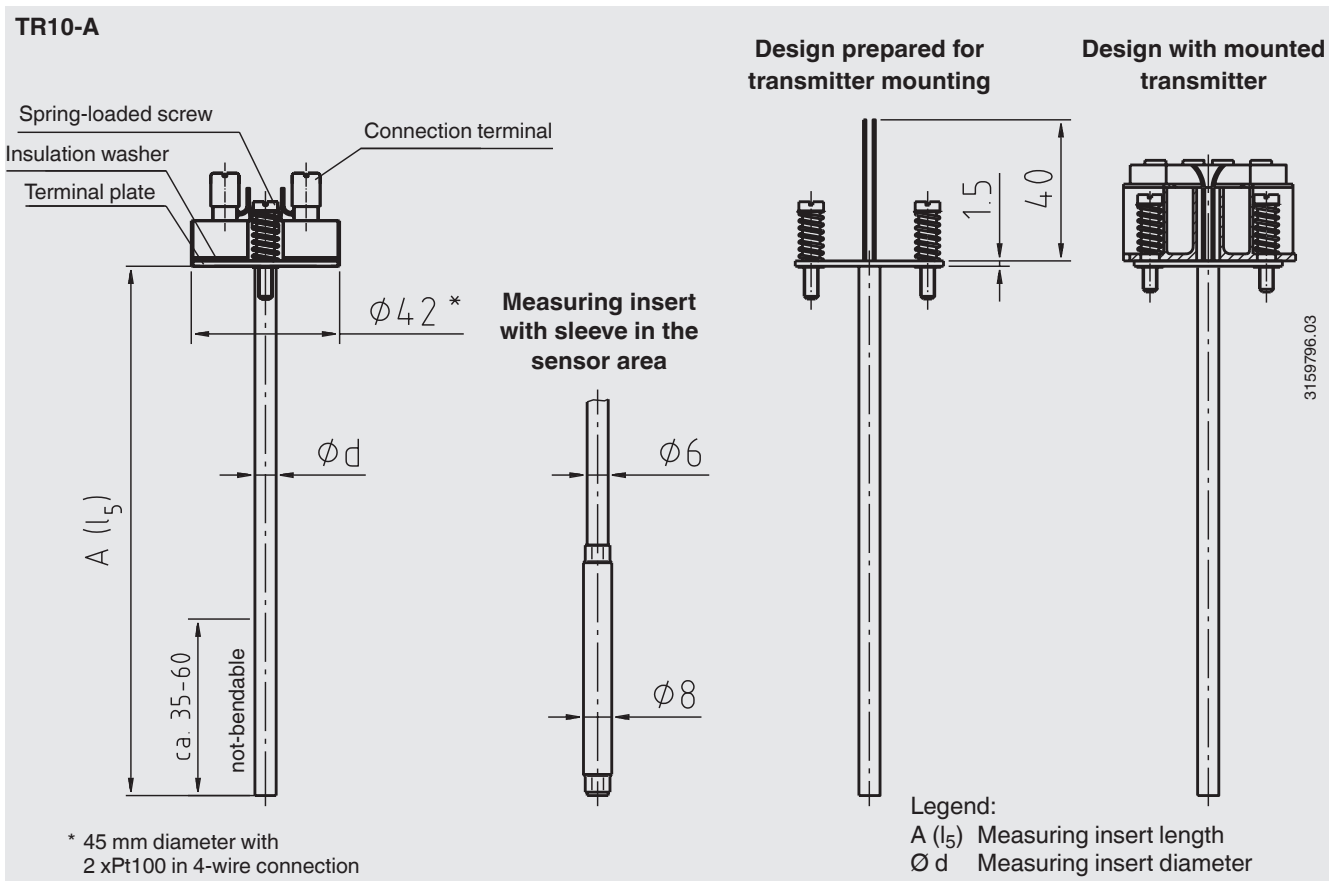

TR10-K (for flameproof enclosure)

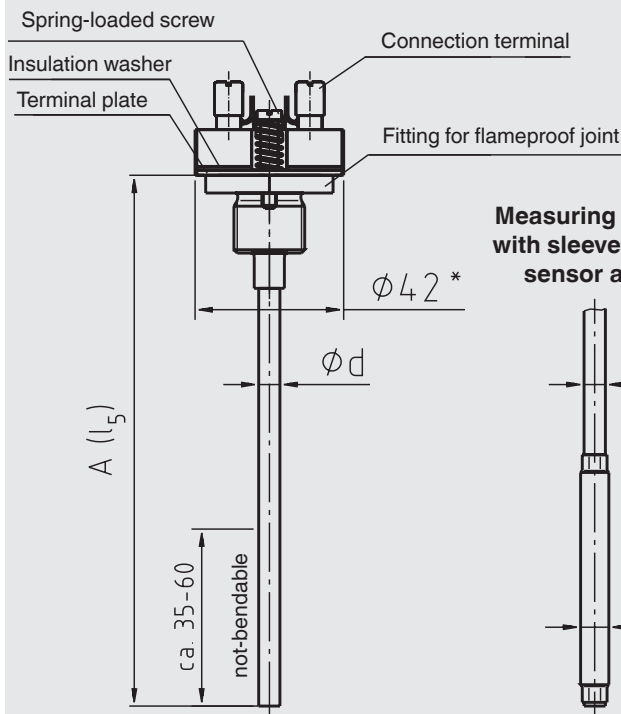

* 45 mm diameter with 2 x Pt100 in 4-wire connection

Design prepared for transmitter mounting

Design with mounted transmitter

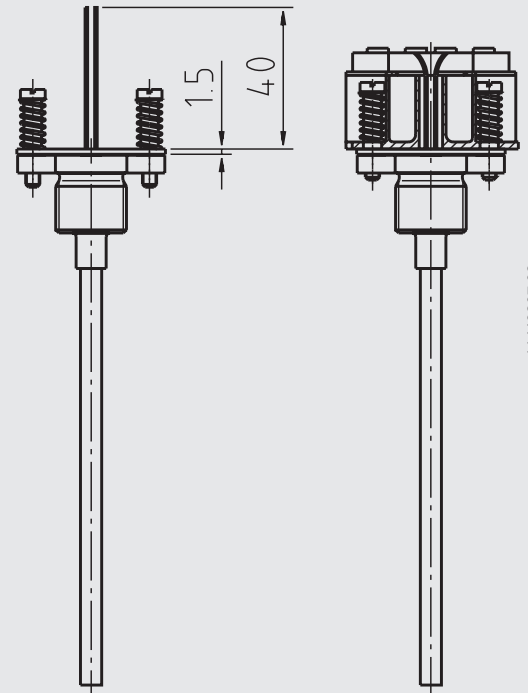

Legend:

$A (l_5)$ Measuring insert length
 ϕd Measuring insert diameter

11449307.02

Standard measuring insert lengths

| Measuring insert ϕ in mm | Standard measuring insert lengths in mm | | | | | | | | | | |
|---------------------------------|---|-----|-----|-----|-----|-----|-----|-----|-----|-----|-----|
| 3 | 275 | 315 | | 375 | | 435 | | | | | |
| 6 | 275 | 315 | 345 | 375 | 405 | 435 | 525 | 555 | 585 | 655 | 735 |
| 8 | 275 | 315 | 345 | 375 | 405 | 435 | 525 | 555 | 585 | 655 | 735 |
| 8 (sleeve) ¹⁾ | 275 | 315 | 345 | 375 | 405 | 435 | 525 | 555 | 585 | 655 | 735 |

The lengths specified in this table correspond to the standard lengths. Intermediate lengths or greater lengths are possible without any difficulty.
 1) MI cable $\phi 6$ mm with sleeve $\phi 8$ mm in the sensor area

Possible combinations of measuring insert diameter, number of sensors and sensor connection method

| Measuring insert ϕ in mm | Sensor / connection method 1 x Pt100 | | | Sensor / connection method 2 x Pt100 | | |
|---------------------------------|--------------------------------------|--------|--------|--------------------------------------|--------|--------|
| | 2-wire | 3-wire | 4-wire | 2-wire | 3-wire | 4-wire |
| 3 | x | x | x | x | x | - |
| 6 | x | x | x | x | x | x |
| 8 | x | x | x | x | x | x |
| 8 (sleeve) ¹⁾ | x | x | x | x | x | x |

The lengths specified in this table correspond to the standard lengths. Intermediate lengths or excess lengths are possible without any problems.
 1) MI cable $\phi 6$ mm with sleeve $\phi 8$ mm in the sensor area

Transmitter (option)

It is possible to build a transmitter onto the measuring insert. Doing so, the transmitter replaces the terminal block and is directly attached to the terminal plate of the measuring insert.

| Model | Description | Explosion protection | Data sheet |
|--------|---|----------------------|------------|
| T19 | Analogue transmitter, configurable | without | TE 19.03 |
| T24 | Analogue transmitter, PC configurable | optional | TE 24.01 |
| T91.10 | Analogue transmitter, fixed measuring range | without | TE 91.01 |
| T12 | Digital transmitter, PC configurable | optional | TE 12.03 |
| T32 | Digital transmitter, HART® protocol | optional | TE 32.04 |
| T53 | Digital transmitter FOUNDATION™ Fieldbus and PROFIBUS® PA | standard | TE 53.01 |

Explosion protection (option)

■ Model TR10-A

Intrinsically safe designs are available for applications in hazardous areas.

These measuring inserts are suitable for mounting (replacement demand) in type-examined thermometers. Manufacturer's declarations in accordance with NAMUR NE24 are also available.

The classification/suitability of the instrument (permissible power, $P_{max.}$, and the permissible ambient temperature) for the respective category can be seen on the EC type-examination certificate and in the operating instructions.

Built-in transmitters have their own EC type-examination certificate. The permissible ambient temperature ranges of the built-in transmitters can be taken from the corresponding transmitter approval.

Attention:

In hazardous areas the use of a model TR10-A measuring insert without a suitable connection head (case) is not permissible!

Where required a suitable thermowell is to be used.

■ Model TR10-K

Attention:

The use of a model TR10-K measuring insert is exclusively allowed if assembled with a flame proof (Ex-d) resistance thermometer model TR10-L!

Only this combination guarantees the correct interaction of connection head, flameproof joint and a - highly precise manufactured – sleeve, which is part of the measuring insert.

Electrical connection

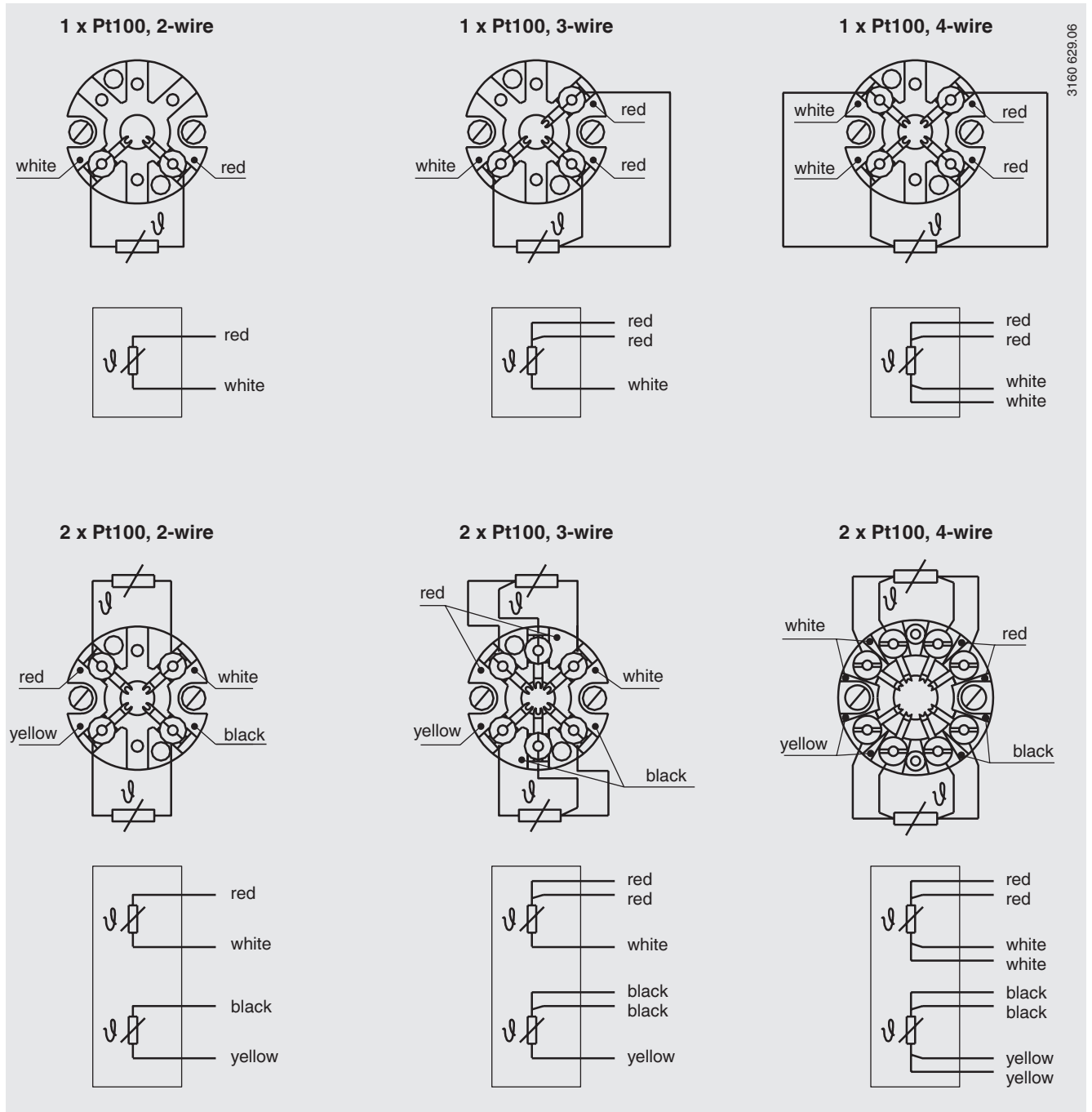

3160 629,06

For the electrical connections of built-in temperature transmitters see the corresponding transmitter data sheets or operating instructions.

© 2003 WIKA Alexander Wiegand SE & Co. KG, all rights reserved.
 The specifications given in this document represent the state of engineering at the time of publishing.
 We reserve the right to make modifications to the specifications and materials.

