

Differential pressure gauge with electrical output signal Universal version, high overpressure safety Models DPGT43HP.100 and DPGT43HP.160

WIKA data sheet PV 17.13



intelliGAUGE®

Applications

- Acquisition and display of process values
- Transmission of process values to the control room (4 ... 20 mA)
- For measuring locations with a high differential pressure overload and/or high working pressures (static pressures), also in aggressive ambience
- Easy-to-read, analogue on-site display needing no external power

Special features

- High working pressure (static pressure) and high overpressure safety, optionally up to 40, 100, 250 or 400 bar
- Individual, non-linear characteristic curves (e. g. x^2 or \sqrt{x} for flow measurement)
- "Plug and play" with no configuration necessary
- Differential pressure measuring ranges from 0 ... 60 mbar
- Hydraulic cushioning protection against rapid pressure changes



Differential pressure gauge model DPGT43HP.100

Description

At any point where a differential pressure has to be indicated locally, and, at the same time, a signal is wanted to be transmitted to a central controller or remote control room, the model DPGT43HP intelliGAUGE (patent applied for, among others European Patent No. EP 06113003) can be used. The electronic WIKA transmitter, integrated into the model 732.14 high-quality mechanical differential pressure gauge, combines the advantages of electrical signal transmission with the advantages of a local mechanical display.

Even if the power supply is completely lost, the differential pressure can be read securely. The rugged design of the diaphragm measuring system produces a pointer rotation proportional to the pressure.

An electronic angle encoder, proven in safety-critical automotive applications, determines the position of the pointer shaft - it is a non-contact sensor and therefore completely free from wear and friction. From this, the electrical output signal

proportional to the pressure, 4 ... 20 mA, is produced. The electrical zero point can also be set manually.

These differential pressure gauges are made of highly corrosion-resistant stainless steel. A high overpressure safety is achieved by the all-metal construction and the close-fitting design of the diaphragm measuring element.

With its high-grade stainless steel construction and robust design this pressure gauge is geared to chemical and process engineering applications. It is suitable for gaseous or liquid media, also in aggressive ambience.

The wetted parts for these differential pressure gauges are available also in special materials such as Monel, Hastelloy or PTFE.

Standard version

Design

highest overpressure safety either side, pressure ratings PN 40, 100, 250 oder 400,
Hydraulic cushioning protection against rapid pressure changes

Nominal size in mm

100, 160

Accuracy class

1.6

Scale ranges

0 ... 60 mbar to 0 ... 250 mbar (measuring cell DN 140)

0 ... 0.4 bar to 0 ... 40 bar (measuring cell DN 80)

With overpressure safety 400 bar: 0 ... 0.4 bar to 0 ... 40 bar
or all other equivalent vacuum or combined pressure and vacuum ranges

Pressure limitation

Steady: Full scale value

Fluctuating: 0.9 x full scale value

Overpressure safety and max. working pressure (static pressure)

either side max. 40, 100, 250 or 400 bar

Pressure elements (wetted)

Stainless steel / NiCrCo-alloy (Duratherm)

Sealings (wetted)

FPM / FKM

Process connections (wetted)

Stainless steel 1.4571,

lower mount (LM)

2 x G ¼ female

Venting of the media chambers (wetted)

Stainless steel 1.4571 for scale ranges ≤ 0.25 bar

(option for scale ranges ≥ 0.4 bar!)

Measuring cell

Chrome steel

Movement

Brass

Dial

Aluminium, white, black lettering

Pointer

Adjustable pointer, aluminium, black (with the liquid filling option: Standard pointer, aluminium, black)

Zero adjustment

By means of adjustable pointer

Case / Bayonet ring

Stainless steel, ingress protection IP 54

Window

Laminated safety glass

Measuring cell filling

Silicone oil

Mounting

according to affixed symbols

⊕ high pressure, ⊖ low pressure

Mounting by means of

- Rigid measuring lines
- Mounting holes in measuring flange
- Panel mounting flange (option)
- Mounting bracket for wall or pipe mounting (option)

Options

- Liquid filling (silicone M50)
- Venting of the media chambers for scale ranges ≥ 0.4 bar
- Measuring cell filling with special medium, e.g. for use in oxygen applications (static pressure max. 100 bar)
- Customer-specific characteristic curve (also non-linear)
- Combined display of differential pressure and working pressure
- Wetted parts made of special material
- Panel mounting flange
- Mounting bracket for wall or pipe mounting, lacquered steel or stainless steel
- Monel version
- Version per ATEX Ex II 2G Ex ia IIC T4 / T5 / T6
- Gost standard approval
- Pressure equalising valve (data sheet AC 09.11)
- Switch contacts (data sheet AC 08.01)

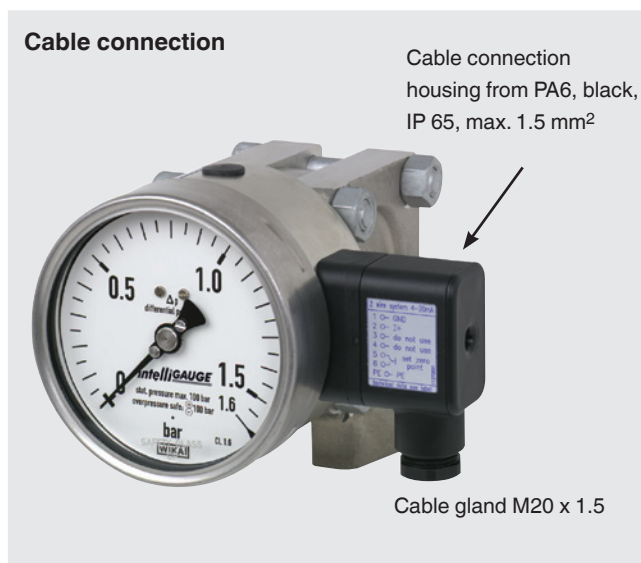

Specifications

intelliGAUGE models DPGT43HP.100, DPGT43HP.160

Electrical data

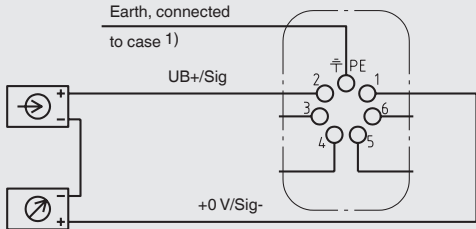
Power supply U_B	DC V	$12 < U_B \leq 30$ (min. 14 with Ex version)
Influence of power supply	% FS/10 V	≤ 0.1
Permissible residual ripple	% ss	≤ 10
Output signal	Variant 1 Variant 2	4 ... 20 mA, 2-wire, passive, per NAMUR NE 43 4 ... 20 mA, per ATEX Ex II 2G Ex ia IIC T4 / T5 / T6
Permissible max. load R_A for variant 1 - 2		$R_A \leq (U_B - 12 \text{ V})/0.02 \text{ A}$ with R_A in Ohm and U_B in Volt, however max. 600 Ω
Effect of load (variant 1 - 2)	% FS	≤ 0.1
Electrical zero point		through a jumper across terminals 5 and 6 (see operating instructions)
■ Long-term stability of electronics	% FS/a	< 0.3
■ Electr. output signal		$\leq 1 \%$ of the measuring span
Linearity	% of span	$\leq 1.0 \%$ (terminal method)
Safety-related maximum values		Ex version
■ Power supply U_i	DC V	max. 30
■ Short circuit current I_i	mA	max. 100
■ Power P_i	W	max. 1
■ Internal capacitance C_i	nF	12
■ Internal inductance L_i	mH	negligible
Electrical connection		Angular connector, 180° rotatable, wire protection, cable gland M20 x 1.5, incl. strain relief, connection cable: Outer diameter 7 - 13 mm, conductor cross-section 0.14 ... 1.5 mm ² , temperature resistance up to 60 °C
Wiring protection		IP 65 per EN 60529 / IEC 529
Assignment of terminals, 2-wire (variants 1 and 2)		 <p>Earth, connected to case 1)</p> <p>UB+/Sig</p> <p>PE</p> <p>+0 V/Sig-</p> <p>Terminals 3, 4, 5 and 6: Only for internal use</p> <p>1) This connection must not be used for equipotential bonding. The instrument must be incorporated in the equipotential bonding via the process connection.</p>

Mechanical data

Display		Nominal size 100 or 160
Scale ranges		
■ Measuring cell DN 140		0 ... 60 mbar to 0 ... 250 mbar
■ Measuring cell DN 80		0 ... 400 mbar to 0 ... 40 bar
Process connection		2 x G ¼ female (others as options)
Damping options		
■ For dynam. pressure load		Restrictor in the pressure channel
■ For vibration		Liquid filling of the case
Operating limits		Overload resistance to EN 837-3
Accuracy		
■ Mechanical display		$\leq 1.6 \%$ of measuring span (class 1.6 per EN 837-3)
Permissible temperature range		
■ Medium	°C	-20 ... +100
■ Ambient	°C	-20 ... +60
Temperature effect	% / 10 K	max. ± 0.5 of full scale value (when the temperature deviates from 20 °C reference temperature)
Case ingress protection		IP 54 per EN 60529 / IEC 529 (with liquid filling IP 65)

Dimensions in mm

Standard version

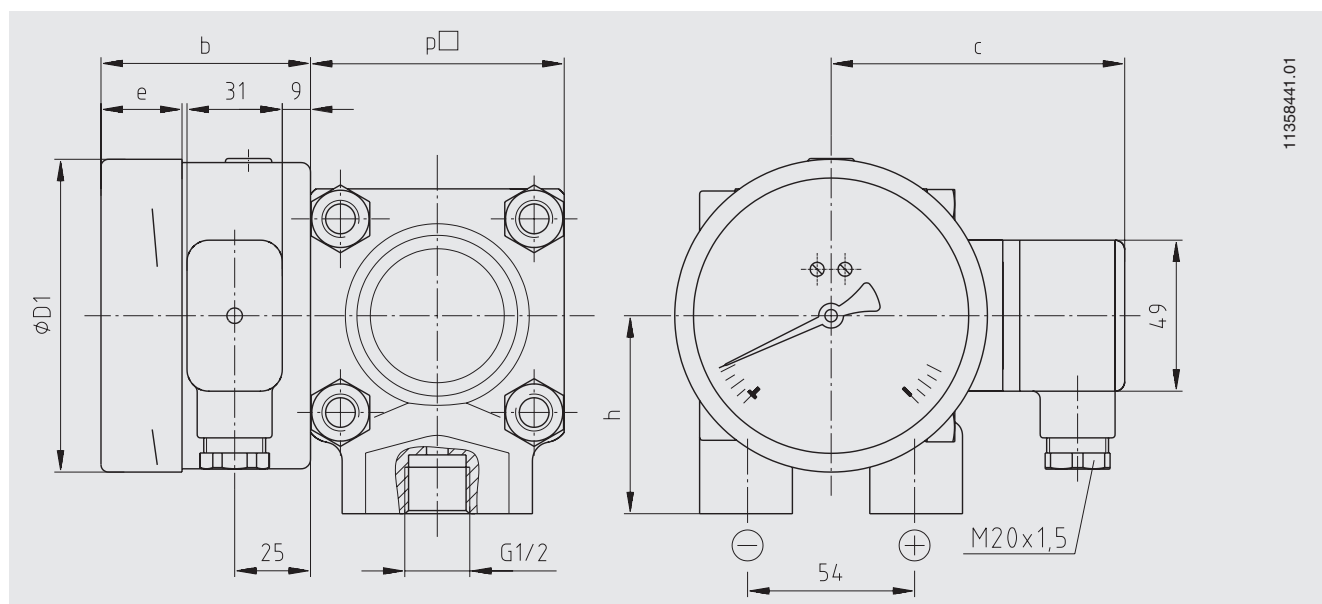

NS	Scale range	Dimensions in mm					Weight in kg		
		b	D1	h ± 1	p□ (PN 40/100/250)	p□ (PN 400)	PN 40/100	PN 250	PN 400
100	≤ 0.25 bar	58.5	101	86	140	-	12.1	13.1	-
100	> 0.25 bar	58.5	101	64	82	86	3.6	3.9	4.5
160	≤ 0.25 bar	65.5	161	86	140	-	12.5	13.5	-
160	> 0.25 bar	65.5	161	64	82	86	4.0	4.3	4.9

Process connection per EN 837

CE conformity

EMC directive

2004/108/EC, EN 61326 emission (group 1, class B) and interference immunity (industrial application)

ATEX directive

94/9/EC, II 2 G Ex ia IIC

Ordering information

Model / Nominal size / Scale range / Connection size / Connection location / Output signal / Scale layout (linear pressure or square root incrementation) / Max. working pressure (static pressure) / Options

© 2008 WIKA Alexander Wiegand SE & Co. KG, alle Rechte vorbehalten.
The specifications given in this document represent the state of engineering at the time of publishing.
We reserve the right to make modifications to the specifications and materials.



WIKAI Alexander Wiegand SE & Co. KG
Alexander-Wiegand-Straße 30
63911 Klingenberg/Germany
Tel. (+49) 9372/132-0
Fax (+49) 9372/132-406
E-mail info@wika.de
www.wika.de