

Temperature Controller for Panel Mounting

PID Controller, Dimensions 48 x 48 mm

Model CS4S

WIKA Data Sheet AC 85.02

Applications

- Plant and industrial furnace construction
- Process engineering
- Plastics technology and processing
- Ventilation and air conditioning technology
- General industrial applications

Special Features

- Control characteristic adjustable (PID, PI, PD, P, ON/OFF)
- Integrated auto-tuning function
- Control output optionally relay, logic level or 4 ... 20 mA
- Multi-function input for Pt100, thermocouples and industry standard signals
- Optionally with 2nd alarm output, heater burnout alarm, 2nd control output, serial interface or parameter memory for a 2nd setting value



Temperature Controller Model CS4S

Description

Model CS4S is a compact digital temperature controller for displaying, controlling and monitoring temperatures.

The controller has a multi-function input, i. e. the input configuration is adjustable.

Thereby the flexibility of the controller is significantly increased, stock-keeping is simplified.

An alarm output for process value monitoring is also available as standard.

The control parameters can be set over wide ranges. An auto-tuning function can be activated, which makes it easier to find the ideal control parameters.

The controllers are designed for panel mounting.

The control output is alternatively equipped with a relay (for slow controls), with a logic level to drive a solid state relay (for fast controls and high current loads) or with an analogue current signal 4 ... 20 mA.

Optionally available are a 2nd alarm output for process value and control loop monitoring as well as a heater burnout alarm or alternatively a 2nd control output. A serial interface RS 485 or a parameter memory for a 2nd setting value is also possible.

The parameter memory is externally selectable via terminals.

Specifications	Model CS4S
----------------	------------

Display	
- Process value	7-segment LED, 4-digit, red, character size 10.2 mm
- Set value	7-segment LED, 4-digit, green, character size 8.8 mm
- Indication range	-1999 ... 9999
Input	
- Number and type	1 multi-function input for resistance thermometers, thermocouples and industry standard signals
- Input configuration	selectable via terminal configuration and menu-driven programming
- Resistance thermometers	Pt100, JPt100, 3-wire, max. permissible resistance per wire: 10 Ω
- Thermocouples	type K, J, R, S, B, E, T, N, PL-II, C (W/Re5-26) max. permissible external resistance: 100 Ω
	for type B: max. 40 Ω
- Standard signals	0 ... 20 mA, 4 ... 20 mA input resistance 50 Ω (external shunt, optionally available) 0 ... 1 V input resistance > 1 MΩ 0 ... 5 V, 1 ... 5 V, 0 ... 10 V input resistance > 100 kΩ
- Measuring time	250 ms
Control output 1	3 different versions are possible
- Relay contact	load: AC 250 V, 3 A (resistive load) AC 250 V, 1 A (inductive load, cos φ = 0.4)
- Logic level	DC 0/12 V max. 40 mA (short-circuit proof) to actuate a solid state relay
{- analogue current signal}	DC 4 ... 20 mA, load max. 550 Ω
Control characteristics	PID, PI, PD, P, ON/OFF (adjustable) An auto-tuning function can be activated to find suitable control parameters.
- Proportional band	thermocouples: 0 ... 1000 °C resistance thermometers: 0.0 ... 999.9 °C standard signals: 0.0 ... 100.0 %
- Integral time	0 ... 1000 s
- Differential time	0 ... 300 s
- Cycle time	1 ... 120 s (not available with control output analogue current signal)
- Hysteresis	only available with ON/OFF control characteristic thermocouples and resistance thermometers: 0.1 ... 100.0 °C standard signals: 1 ... 1000 (the placement of the decimal point follows the input configuration)
{Control output 2} ¹⁾	for three-step control
- Output	non contact relay, load: AC 230 V, 0.3 A (resistive load)
- Proportional band	0.0 up to 10.0 times the proportional band of control output 1
- Integral time	identical with the integral time of control output 1
- Differential time	identical with the differential time of control output 1
- Cycle time	1 ... 120 s
- Overlap- /Dead band	thermocouples and resistance thermometers: -100.0 ... 100.0 °C standard signals: -1000 ... 1000 (the placement of the decimal point follows the input configuration)
- Hysteresis	only available with ON/OFF control characteristic thermocouples and resistance thermometers: 0.1 ... 100.0 °C standard signals: 1 ... 1000 (the placement of the decimal point follows the input configuration)
Alarm outputs	max. 2 pieces (common contact root)
- Alarm output 1	for process value monitoring alarm type, switching mode, hysteresis and delay adjustable
- {Alarm output 2} ¹⁾²⁾	alternatively for process value monitoring or control loop monitoring or process value and control loop monitoring with combined output
- {Heater burnout alarm} ¹⁾²⁾	for 1 phase heating systems (not available with control output analogue current signal) alternatively for max. 5 A, 10 A, 20 A or 50 A, current transformer is supplied with controller
- Relay contact ³⁾	load: AC 250 V, 3 A (resistive load) AC 250 V, 1 A (inductive load, cos φ = 0.4)

{ } Items in curved brackets are optional extras for an additional price.

1) A combination of alarm output 2 or heater burnout alarm with control output 2 is not possible.

2) In case of combination of alarm output 2 and heater burnout alarm they act on a common relay output.

3) Valid for alarm output 1 and alarm output 2 resp. heater burnout alarm.

Specifications (Continuation)	Model CS4S
{Parameter memory} ⁴⁾	Memory for a 2nd set value, activated by short-circuiting of two connection terminals at the back of the controller
{Serial interface} ⁴⁾	RS-485 The transfer rate is adjustable (2400 bps, 4800 bps, 9600 bps or 19200 bps)
Power supply	AC 100 ... 240 V, 50/60 Hz (max. permissible 85 ... 264 V) or AC/DC 24 V, 50/60 Hz (max. permissible 20 ... 28 V)
Power consumption	approx. 8 VA
Ambient conditions	
- Ambient temperature	0 ... 50 °C
- Storage temperature	-20 ... +50 °C
- Humidity	35 ... 85 % relative humidity, non-condensing
Case	
- Material	polycarbonate
- Colour	black
- Ingress protection	front: IP66, back: IP00 (per IEC 60529/EN 60 529)
- Mass	approx. 200 g
- Mounting	screw bracket for a panel thickness of 1 up to 15 mm

{ } Items in curved brackets are optional extras for an additional price.

4) From the options serial interface and parameter memory only one option can be selected.

Input signals	Measuring span		Measuring error in [%] of the span	
			Standard	Exception
Current signals				
0 ... 20 mA	-1999 ... 9999 ⁵⁾		± 0.2 % ± 1 digit	-
4 ... 20 mA	-1999 ... 9999 ⁵⁾		± 0.2 % ± 1 digit	-
Voltage signals				
0 ... 1 V	-1999 ... 9999 ⁵⁾		± 0.2 % ± 1 digit	-
0 ... 5 V	-1999 ... 9999 ⁵⁾		± 0.2 % ± 1 digit	-
1 ... 5 V	-1999 ... 9999 ⁵⁾		± 0.2 % ± 1 digit	-
0 ... 10 V	-1999 ... 9999 ⁵⁾		± 0.2 % ± 1 digit	-
Thermocouples				
Type K, NiCr-Ni	-200 ... +1370 °C	-320 ... +2500 °F	± 0.2 % ± 1 digit ⁶⁾	≤ 0 °C: ± 0.4 % ± 1 digit
	-199.9 ... +400.0 °C	-199.9 ... +750.0 °F	± 2 K	≤ 0 °C: ± 0.4 % ± 1 digit
Type J, Fe-CuNi	-200 ... +1000 °C	-320 ... +1800 °F	± 0.2 % ± 1 digit ⁶⁾	≤ 0 °C: ± 0.4 % ± 1 digit
Type R, PtRh-Pt	0 ... 1760 °C	0 ... 3200 °F	± 0.2 % ± 1 digit ⁶⁾	≤ 200 °C: ± 6 K
Type S, PtRh-Pt	0 ... 1760 °C	0 ... 3200 °F	± 0.2 % ± 1 digit ⁶⁾	≤ 200 °C: ± 6 K
Type B, PtRh-PtRh	0 ... 1820 °C	0 ... 3300 °F	± 0.2 % ± 1 digit ⁶⁾	≤ 300 °C: not specified
Type E, NiCr-CuNi	-200 ... +800 °C	-320 ... +1500 °F	± 0.2 % ± 1 digit ⁶⁾	≤ 0 °C: ± 0.4 % ± 1 digit
Type T, Cu-CuNi	-199.9 ... +400.0 °C	-199.9 ... +750.0 °F	± 2 K	≤ 0 °C: ± 0.4 % ± 1 digit
Type N, NiCrSi-NiSi	-200 ... +1300 °C	-320 ... +2300 °F	± 0.2 % ± 1 digit ⁶⁾	≤ 0 °C: ± 0.4 % ± 1 digit
Type PL-II	0 ... 1390 °C	0 ... 2500 °F	± 0.2 % ± 1 digit ⁶⁾	-
Type C (W/Re5-26)	0 ... 2315 °C	0 ... 4200 °F	± 0.2 % ± 1 digit ⁶⁾	-
Resistance thermometers				
Pt100 (3-wire)	-200 ... +850 °C	-300 ... +1500 °F	± 0.1 % ± 1 digit ⁶⁾	-
	-199.9 ... +850.0 °C	-199.9 ... +999.9 °F	± 0.1 % ± 1 digit ⁶⁾	-
JPt100 (3-wire)	-200 ... +500 °C	-300 ... +900 °F	± 0.1 % ± 1 digit ⁶⁾	-
	-199.9 ... +500.0 °C	-199.9 ... +900.0 °F	± 1 K	-

5) Decimal point adjustable

6) Referring to the measuring span in °C.

Terminal arrangement

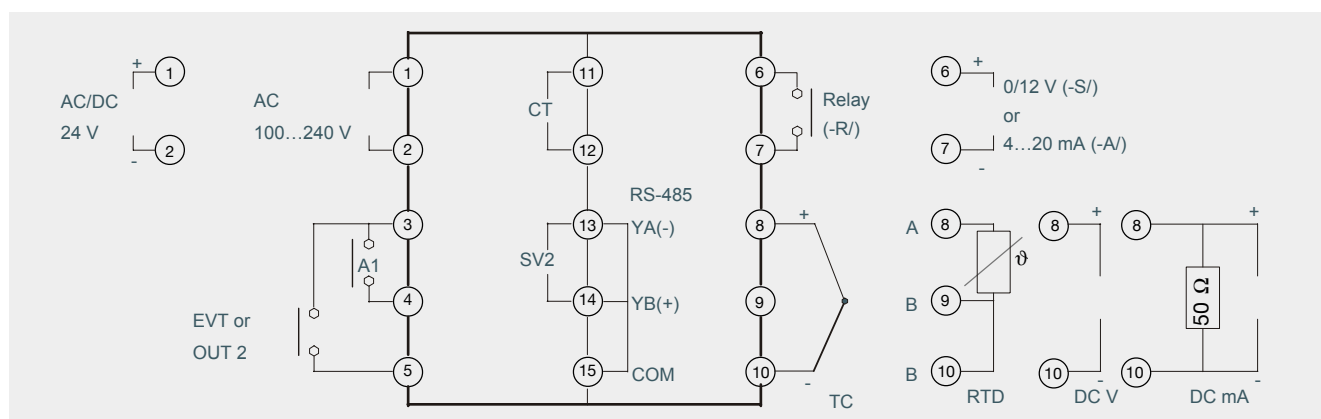

Legend:

A1	Alarm output 1	(-R/)	Control output relay
EVT	Output for alarm output 2 and heater burnout alarm	(-S/)	Control output logic level 0/12 V
OUT 2	2nd control output	(-A/)	Control output analogue current signal 4 ... 20 mA
CT	Current transformer for heater burnout alarm	TC	Input thermocouple
SV2	Parameter memory for 2nd set value	RTD	Input RTD
RS-485	Serial interface RS-485	DC V	Input voltage signal
		DC mA	Input current signal

Dimensions in mm

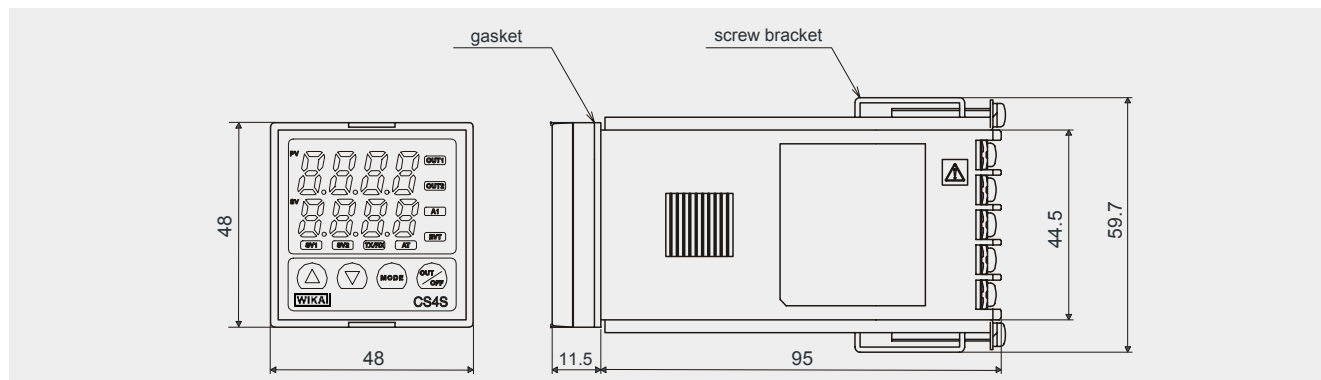

Panel cutout in mm

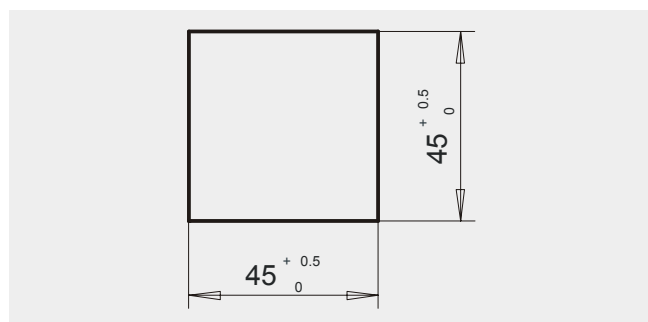

Modifications may take place and materials specified may be replaced by others without prior notice. Specifications and dimensions given in this leaflet represent the state of engineering at the time of printing.



WIKAI Alexander Wiegand GmbH & Co. KG
 Alexander-Wiegand-Straße 30
 63911 Klingenberg / Germany
 Telefon (+49) 93 72/132-9986
 Telefax (+49) 93 72/132-217
 E-Mail testequip@wika.de
 www.wika.de