

Pressure Gauge Syphons Model 910.15

WIKA Data Sheet AC 09.06

Applications

- Pressure gauge syphons protect pressure gauges from the effect of rapid pressure surges and hot pressure media
- Cooling element for liquids, gases and vapours in pressure measuring applications
- For direct mounting to the pressure connection of the pressure gauge or to the shut-off device (pressure gauge cock or valve) underneath

Special Features

- Designs per DIN 16 282 or industrial standard designs
- Max. temperatures up to 400 °C
- Nominal pressures up to 160 bar
- Materials: carbon steel (1.0039, 1.0345) and stainless steel 1.4571

Description

Pressure gauge syphons per DIN 16 282 U-form, form B, and trumpet form, form D, have a welding connection for pressure tapping on the process side and a threaded connection on the pressure gauge side.

In the „industrial standard“ versions threaded connections are also available for pressure tapping on the process side.

U-form pressure gauge syphons are intended for horizontal pressure tapping, trumpet form syphons are intended for vertical pressure tapping.

Inside the syphon condensate is collected, which prevents the penetration of hot media into the gauge.

We recommend filling the syphon with a cooling separating liquid before commissioning the pressure line.



Pressure gauge syphons DIN 16 282, stainless steel
Fig. left: U-form, form B
Fig. right: trumpet form, form D

Max. working temperatures/pressures

Material	Max. working temperature up to °C	Max. working pressure ¹⁾ in bar
Carbon steel	120	160
1.0039, 1.0345	300	120
	400	104
Stainless steel	120	160
1.4571	300	140
	400	131



1) With some industrial standard pressure gauge syphons the max. working pressure is limited to 25 bar, see table on page 3

Options

- Other connection thread
- Special steel alloy for high temperatures and working pressures
- Material Monel
- Stainless steel 1.4571 degreased for oxygen
- Material test certificate 3.1 / 3.2
- Pipe connectors for pressure gauges, see page 3

1. Designs per DIN 16 282

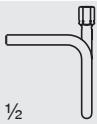
With welding connection on the process side

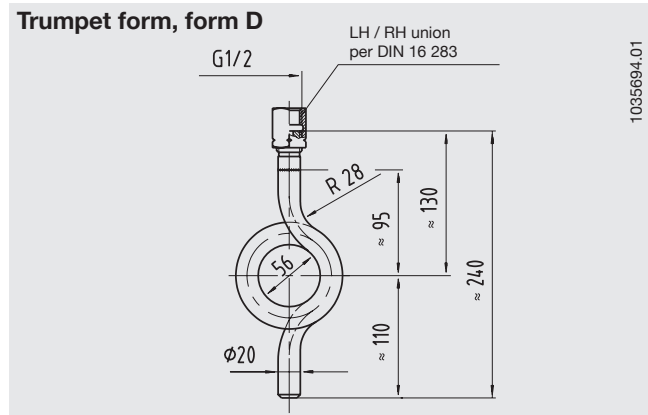
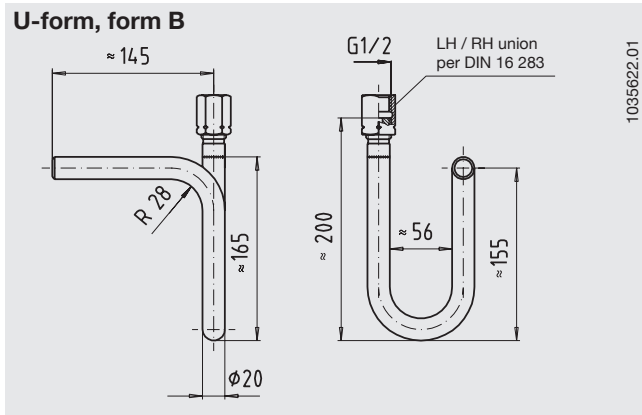

Design	Material	Order no.
U-form, form B  Gauge side: LH / RH union G 1/2	1.0345	9091190
	1.0345 with 3.1	2057876
	1.4571	1323270
	1.4571 with 3.1	2194023
Trumpet form, form D  Gauge side: LH / RH union G 1/2	1.0345	9091211
	1.0345 with 3.1	1614940
	1.4571	1440497
	1.4571 with 3.1	1614924

Dimensions in mm



2. Industrial standard designs (similar to DIN 16 282)

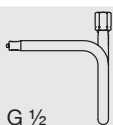

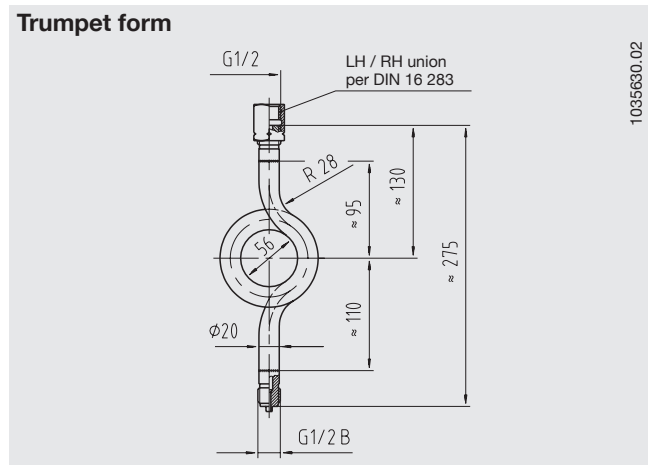
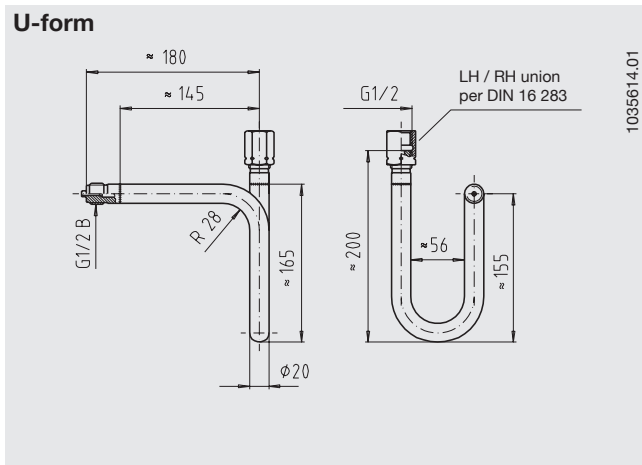

With threaded connection G 1/2 B on the process side

Design	Material	Order no.
U-form  Gauge side: LH / RH union G 1/2	1.0345	9091181
	1.0345 with 3.1	on inquiry
	1.4571	9091220
	1.4571 with 3.1	2057841
Trumpet form  Gauge side: LH / RH union G 1/2	1.0345	9091203
	1.0345 with 3.1	2329039
	1.4571	9091238
	1.4571 with 3.1	1323997
LH / RH union G 1/2	1.4571 w. 3.1 NACE	1323997

Dimensions in mm

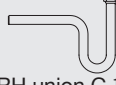

3. Industrial standard designs

Design	Connection thread G	Max. working pressure	Material	Dimensions in mm						Order no.
				D	h	h ₁	l	u	s	
U-form 	G 1/4 B ²⁾	25 bar	1.0039	-	170	130	225	60	13	9090649
	G 1/2 B ²⁾	25 bar	1.0345	-	170	130	225	56	20	9090657
Both sides: thread (male)										
U-form 	G 1/2 B ²⁾	25 bar	1.0345	-	205	130	225	56	20	9090665
	Entry: G 1/2 B Gauge side: LH / RH union G 1/2	see page 1	1.0345	-	200	130	225	56	20	9090673
U-form 	G 1/2 B	see page 1	1.0345	-	200	130	-	56	-	9090681
	Entry: butt welding ¹⁾ Gauge side: LH/RH union G 1/2									
Trumpet form 	G 1/4 B ²⁾	25 bar	1.0039	60	240	120	-	-	13	9090592
	G 1/2 B ²⁾	25 bar	1.0345	56	230	115	-	-	20	9090606
Both sides: thread (male)										

- 1) Chamfered for root welding.
- 2) Thread machined on pipe.
- 3) Pressure connection welded

Dimensions in mm

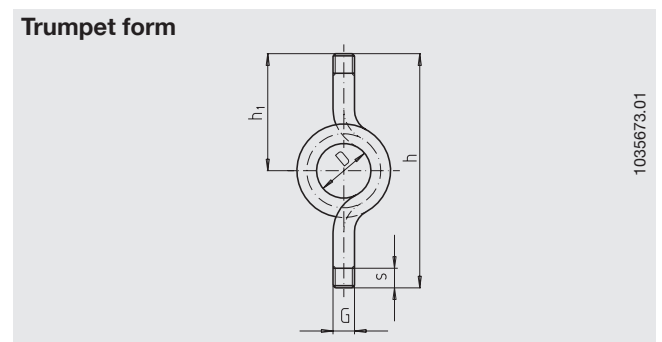
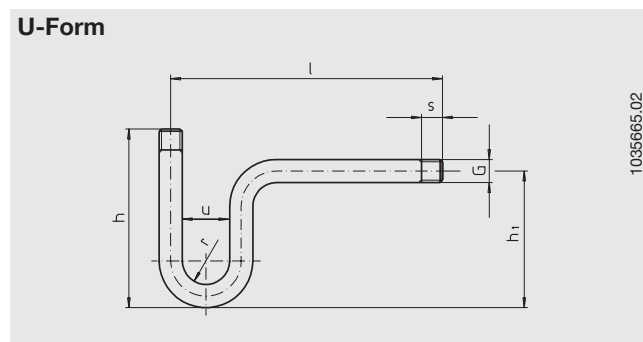

4. Pipe connectors for pressure gauges

Welding connection on the process side (Gauge side: LH / RH union G 1/2)

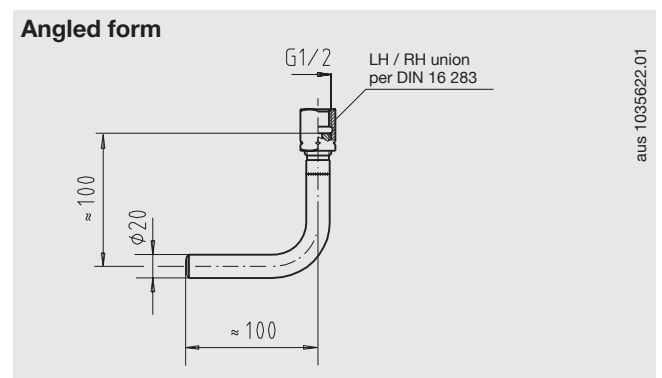
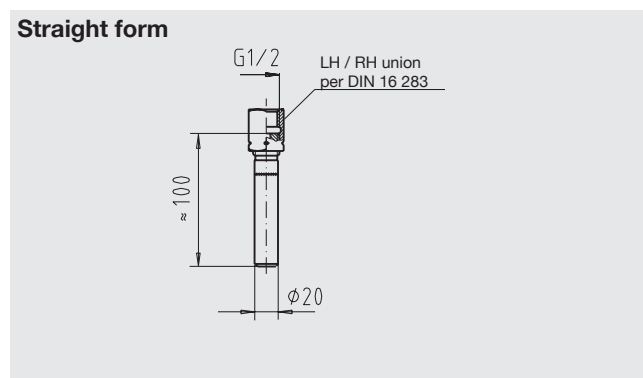

Design	Material	Order no.
Straight form	1.0345	2243679
	1.4571	2112892

Design	Material	Order no.
Angled form	1.0345	2243687
	1.4571	2003612

Ordering information

To order the described products the 7-digit order number is sufficient. Options should be stated separately.

Specifications and dimensions given in this leaflet represent the state of engineering at the time of printing.
Modifications may take place and materials specified may be replaced by others without prior notice.



WIKAI Alexander Wiegand GmbH & Co. KG
Alexander-Wiegand-Straße 30
63911 Klingenberg/Germany
Tel. (+49) 9372/132-0
Fax (+49) 9372/132-406
E-mail info@wika.de
www.wika.de